



Temperature&Humidity Sensor

TS30x

User Guide

Contents

Chapter 1. Preface.....	4
Chapter 2. Product Introduction.....	6
Overview.....	6
Packing List.....	7
Hardware Components.....	7
Hardware Overview.....	7
Button Descriptions.....	8
Screen Description.....	9
Dimensions(mm).....	10
Chapter 3. Hardware Installation.....	11
Install the Device.....	11
Wall Plugs and Screw Mounting.....	11
Magnetic Mounting (Optional).....	11
Magnet Switch Installation.....	12
Thermal Buffer Bottle (Alternative).....	13
Battery Replacement.....	14
Chapter 4. ToolBox App Configuration.....	16
Access the Device Using NFC.....	16
Synchronize Device Time.....	17
Configure LoRaWAN® Parameters.....	19
Configure the Joining Type and the Frequency.....	19
Configure Basic Network Parameters.....	22
Configure the Milesight D2D Parameters.....	25
Configure the Device Parameters.....	29
Change the Device Password.....	29
Configure Basic Device Parameters.....	30
Configure the Data Storage & Retransmission.....	32

Configure Calibration Parameters.....	35
Configure the Threshold Parameters.....	37
Maintain the Device.....	42
Upgrade.....	42
Configure a Template for Configuration Backup.....	43
Reset the Device.....	46
Chapter 5. Uplink Packets and Downlink Commands.....	48
Uplink Packets.....	48
Basic Information Packet.....	48
Periodically Reported Data Packet.....	49
Probe ID Report.....	50
Alarm Report.....	51
Downlink Commands.....	54
Commands for General Setting.....	54
Commands for Time Settings.....	56
Commands for Calibration Settings.....	57
Commands for Threshold Settings.....	58
Commands for D2D Setting.....	61
Commands for Configuration Query.....	63
Commands for Historical Data Query.....	66
Chapter 6. Services.....	70

Chapter 1. Preface

Copyright Statement

This guide may not be reproduced in any form or by any means to create any derivative such as translation, transformation, or adaptation without the prior written permission of Xiamen Milesight IoT Co., Ltd (Hereinafter referred to as Milesight).

Milesight reserves the right to change this guide and the specifications without prior notice. The latest specifications and user documentation for all Milesight products are available on our official website <http://www.milesight.com>

Safety Instruction

These instructions are intended to ensure that user can use the product correctly to avoid danger or property loss. Milesight will not shoulder responsibility for any loss or damage resulting from not following the instructions of this operating guide.

 **Warning:**

Serious injury or death may be caused if any of these warnings is neglected.

- The PT100 temperature probe has a sharp point. Please be careful and keep the edges and points away from human body.

 **CAUTION:**

Injury or equipment damage may be caused if any of these cautions are neglected.

- The device must not be disassembled or remodeled in any way.
- To ensure the security of your device, please change the device password during the initial configuration. The default password is 123456.
- The device is not intended to be used as a reference sensor, and Milesight will not should responsibility for any damage which may result from inaccurate readings.
- Do not place the device close to objects with naked flames.
- Do not operate the device outside its specified temperature range.
- Make sure electronic components do not drop out of the enclosure while opening.



- When installing the battery, please install it accurately, and do not install the inverse or wrong model.
- The device must never be subjected to shocks or impacts.

Revision History

Release Date	Version	Description
October 23, 2023	V1.0	Initial version
January 5, 2026	V2.0	<ol style="list-style-type: none"> 1. Compatible with TH and DS18B20 probes. 2. Support FUOTA feature. 3. Support Milesight D2D Data Transmission and Controller feature. 4. Support data collection and reporting via button. 5. Support magnetic contact switch alarm delay. 6. Support to configure time zone and DST time. 7. Support sending downlink commands to query configuration.

Chapter 2. Product Introduction

This chapter describes basic product information.

Overview

TS30x is a compact temperature sensor with a visualized data display. It features extendable connecting lines, a diverse range of detecting probes, and an IP65 waterproof design, making it applicable for accurate temperature and humidity data detection in various harsh environments. Moreover, it provides the option for a magnetic contact switch sensor. TS30x prioritizes security and reliability, ensuring traceable data and effortless data exports for seamless integration.

TS30x is designed for measuring a wide range of temperature in harsh environments and transmitting data using LoRaWAN[®] technology. With this low power consumption technology, TS30x can maintain a long operational life with its embedded batteries. Combining with Milesight LoRaWAN[®] gateway, users can manage all sensor data remotely and visually.

TS30x is widely used for temperature and humidity monitoring applications like food processing, cold chain storage of food or medicine, etc.

It has the following features:

- Provides optional high accuracy PT100 temperature probes, DS18B20 temperature probe and TH temperature - humidity probe
- Detachable probe for self-calibration
- IP65 waterproof enclosure with dust plug, suitable for harsh environment
- Support automated temperature monitoring and anti-tamper recording of data in compliance with HACCP, meeting the authenticity requirements of 21 CFR Part 11B electronic record
- Complies with EN12830 regulation, applicable for cold-chain applications
- Provide simplified PDF data export for easy documentation without complex paperwork
- Built-in two large-capacity replaceable batteries, ensuring an extended battery life
- Features low-consumption LCD display, enabling intuitive data reading
- Store historical records locally and supports retransmission to prevent data loss
- Equipped with NFC for quick and easy configuration
- Function effectively with standard LoRaWAN[®] gateways and network servers
- Compatible with Milesight Development Platform
- Supports Milesight D2D protocol to enable ultra-low latency and direct control without gateways
- Supports Firmware Update Over the Air (FUOTA) feature

Packing List

This chapter describes the packing list. You can verify the contents against the following list to ensure all items are present. If any of them is missing or damaged, you can contact your sales representative.

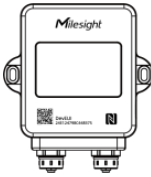

1 × TS30x Device



2 × Mounting Kits



2 × Screw Caps



1 × Quick Start Guide



1 × Warranty Card

Optional Sensor:



Temperature (Humidity) Probe

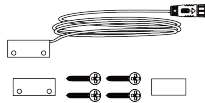

Magnet Switch Sensor (With 3M Tapes and Mounting Screws)

Sensor Accessories



1 × Type-C Cable (1.2m)
& Power Adapter

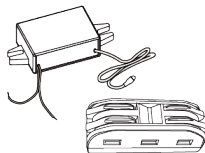

1 × AC/DC-DC Power Converter Kit



Glass Bead Thermal Buffer Bottle

Hardware Components

Hardware Overview

The following figure shows the main components of the device.

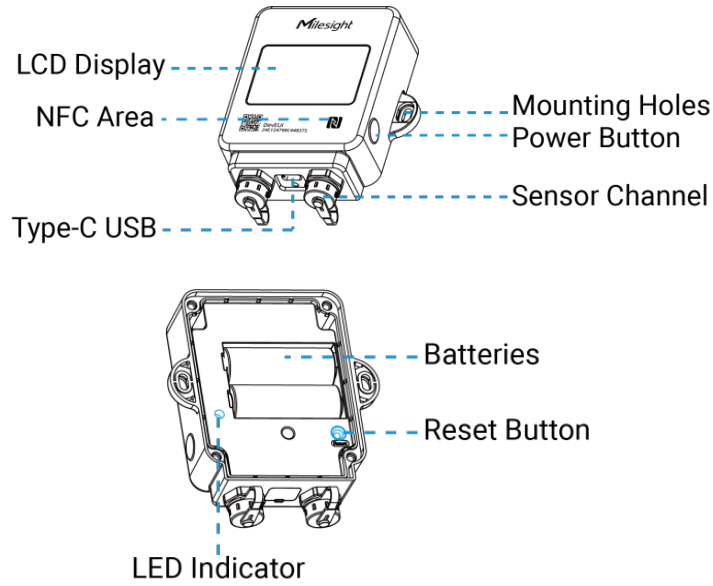

For the description of each component, refer to the following table.

Name	Description
NFC Area	Allows for wireless configuration through mobile phone NFC.
Mounting Holes	Used for securing the device.
Power Button	Controls device power on/off or data reporting.
Type-C USB	Used for data export.
Batteries	Houses the battery for power supply.
LCD Display	Displays device status and information.
LED Indicator	Indicates the device status.
Sensor Channel	Interface for connecting external sensors.

Button Descriptions

Power Button

Function	Action	LCD Display
Power On	Press and hold the button for more than 3 seconds.	Off → On
Power Off		On → Off







Function	Action	LCD Display
Update Temperature (Humidity)	Quick press the power button once	Update the latest temperature (humidity) of the current channel
Switch Channel Display (TS302 dual temp/humidity version only)	Quick press the power button twice	Display another channel's latest temperature

Reset Button

Function	Action	LED Indicator
Reset to Factory Default	Press and hold the reset button for more than 10 seconds	Blinks quickly

Screen Description

The screen is only displayed when the temperature sensor is connected to the TS30x, and the screen is turned off when no sensor is connected or only when connected to the magnet switch sensor. It can be enabled/disabled by downlink commands.

Icon	Description
	Time
	Appears when the temperature/humidity threshold alarm is triggered
	Door Opening Alarm
	Battery level
	Appears when the LoRaWAN [®] network is activated
	Display the temperature value

Icon	Description
	Display the humidity value when connecting to the TH probe

Dimensions(mm)

The following figure shows the device dimensions (unit: mm).

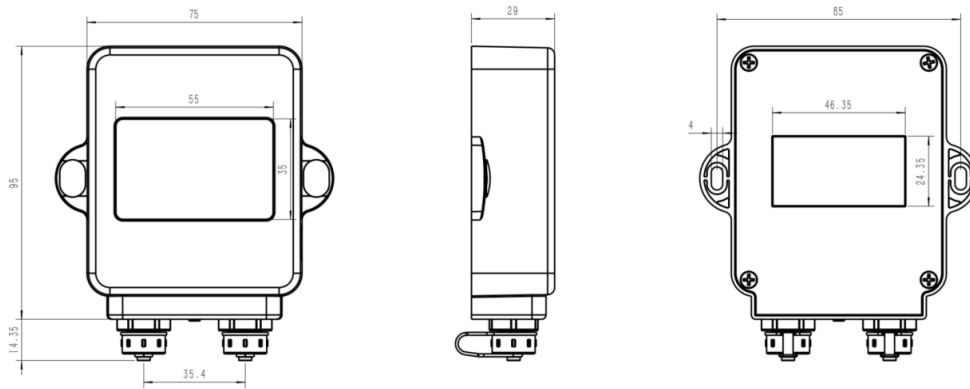

Chapter 3. Hardware Installation

This section describes how to install the accessories and device.

Install the Device

Wall Plugs and Screw Mounting

Preparation:

- Mounting kits
- Screw caps
- Electric drill

Steps:

1. Fix the wall plugs to a flat surface according to the mounting holes.
2. Secure the device to the wall plugs using screws (screw torsion: $\leq 3\text{kgf}\cdot\text{cm}$).
3. (Optional) Cover the screws with cover caps.



Note:

When installing, please ensure the LCD display is positioned vertically on the ground below eye level for clear visibility of the content.

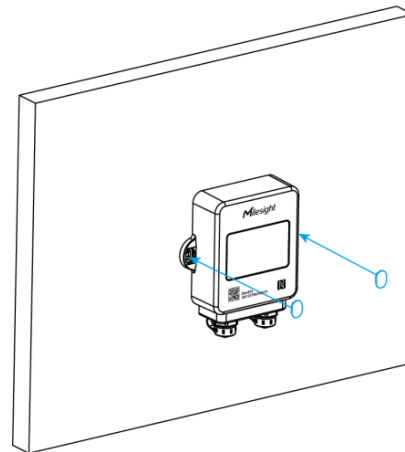
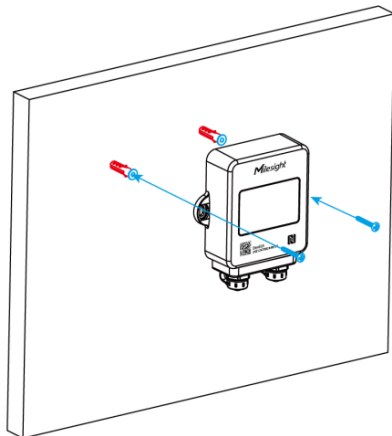

Magnetic Mounting (Optional)

Preparation:

- Magnetic nut
- Wall screw
- Screw caps

Steps:

1. Insert the screw through the device and secure it to the magnetic nut.
2. Afterward affix the entire assembly to the flat surface.
3. (Optional) Cover the screws with cover caps.



Note:

When installing, please ensure the LCD display is positioned vertically on the ground below eye level for clear visibility of the content.

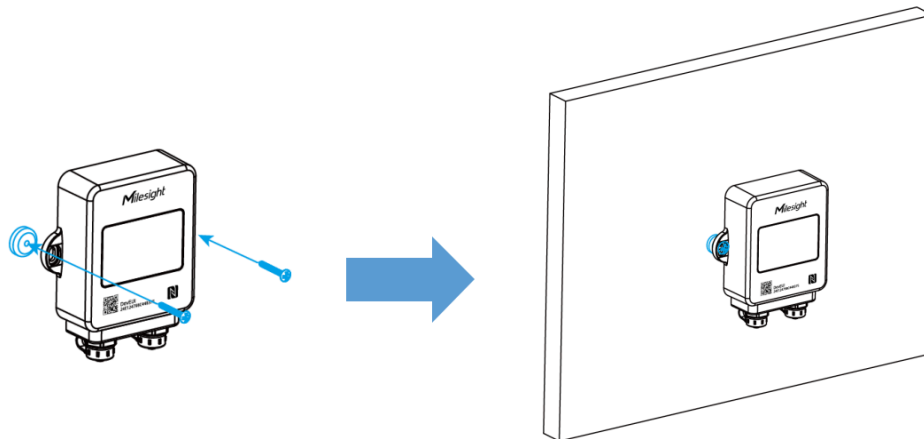

Magnet Switch Installation

Preparation:

- Magnet switch sensor (with 3M tapes and mounting screws)

Installation Locations:

- Doors, windows and any facilities to detect open/close status.
- Do not install the magnets to or close to iron objects.

Steps:

1. Put the two magnet parts to target location and mark the location as needed. To ensure the best detection, both parts should be aligned and the holes of magnets should be faced outside.

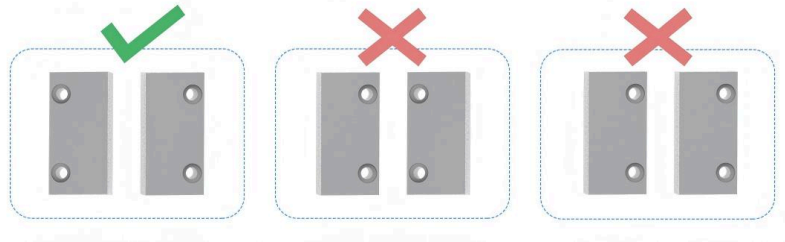

2. Fix the two magnet parts with 3M tape or screws.

Fixed by Screws:

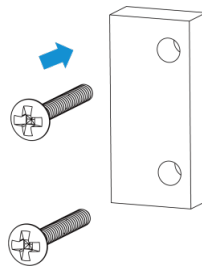

Fixed by 3M Tape:

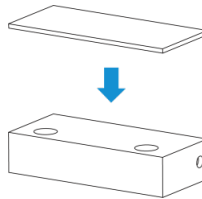

3. Check if the two parts are aligned.

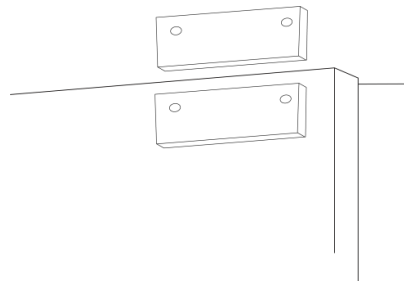

Thermal Buffer Bottle (Alternative)

This setup allows for more accurate temperature measurements and makes it suitable for placement in location such as freezers and refrigerators.

Steps:

1. Unplug the stopper inside the bottle cap.

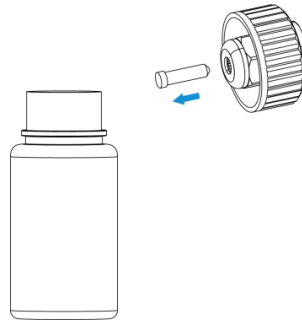

2. Restore the cap and insert the PT100 probe into the bottle.

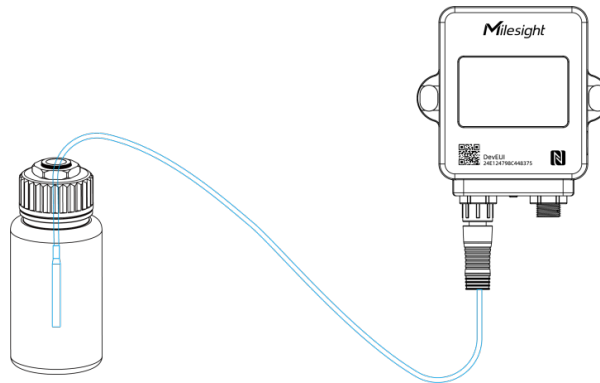

Battery Replacement

This chapter describes how to replace the batteries when the device runs out of power. Remove batteries from the device if it is not used for an extended period.

Battery Requirements:

- Power the device by ER18505 Li-SoCl₂ batteries. Alkaline batteries are not supported.
- Always replace with new batteries. Using old batteries may reduce battery life or lead to inaccurate power level calculations.

Steps:

1. Remove the back cover.
2. Replace the battery correctly, ensuring proper orientation and model compatibility.

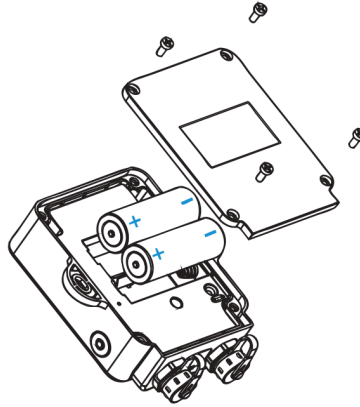

Chapter 4. ToolBox App Configuration

The Milesight ToolBox app can be used to configure the device. This chapter describes ToolBox related configuration.

Access the Device Using NFC

This section describes how to access the device using NFC.

Steps:

1. Download Milesight ToolBox app from Google Play or Apple Store.
2. Enable the NFC function on the smart phone.
3. Launch ToolBox.
 - a. Upon first launch, the following page is displayed. Select **NFC** and click **Enter**.

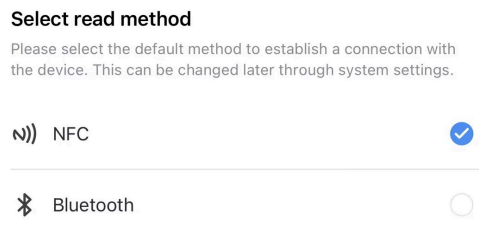

- b. Upon subsequent launches, Click **Maintenance** on the home page, and then select **NFC**.

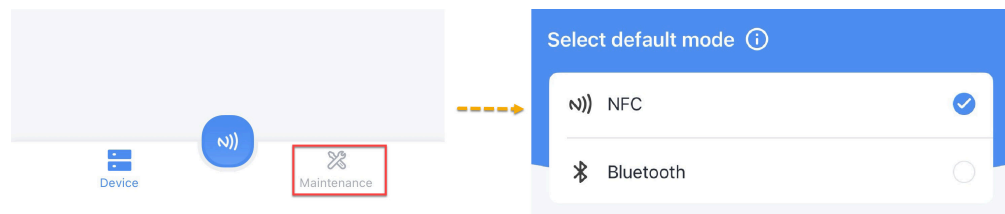



4. (Optional) To locate the NFC detection areas of the phone and the device, click **Can't find the NFC location**.
5. Put the NFC detection area of the phone close to the NFC antenna of the device.

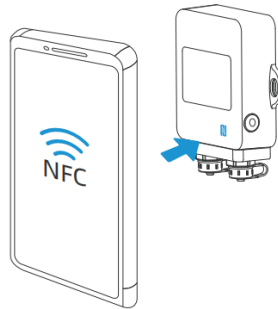

Tip:

It is recommended to take off the phone case.





- Click . If the device is recognized successfully, the homepage is displayed.



Troubleshooting:

If read fails, move the phone away and reposition it close to the sensor to try again.

For a description of the homepage, refer to the following table.

Item	Description
Basic Information	Shows basic device information and sync the system time.
Setting	Sets the device and network parameters.
	Imports, adds, exports or deletes a template.
	Sets the language, shows NFC positions and checks the version.

Synchronize Device Time

This section describes how to sync the device time.

Synchronize the Time Manually Through ToolBox

The device time can be synced via Milesight ToolBox App.

Steps:

1. On the homepage of ToolBox, click **Basic Information**.
2. Click  to synchronize the time.

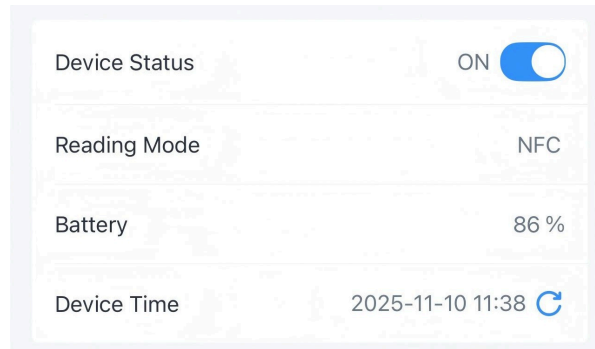

3. Put the NFC detection area of the phone close to the NFC antenna of the device. If the time is synchronized successfully, the following page is displayed.



Sync successfully!

Synchronize the Time Automatically Through a LoRaWAN[®] Network Server

Prerequisite: The LoRaWAN[®] network server supports the device time synchronization feature.

Steps:

1. Set the LoRaWAN[®] version of the device to **V1.0.3**. For details, refer to [Configure Basic Network Parameters](#).
2. Connect the device to the network server. Once the device successfully joins the network, it sends a MAC command to query the time from the network server.



Note:

- This only supports to get the time but not time zone. The time zone can be configured by ToolBox App or downlink command.
- The device will send the DeviceTimeReq command every 5 days since the last sync.

Configure LoRaWAN® Parameters

This section describes how to configure the device transmission parameters for the LoRaWAN® network. Among them, the joining type and the frequency must be configured. Otherwise, the device cannot join the network.

Configure the Joining Type and the Frequency

This section describes how to configure the joining type and the frequency.

Steps:

1. On the homepage of ToolBox, click **Setting** to enter the **Setting** page.
2. Click **Network**. The **Network** page is displayed, see the following figure.

The screenshot displays the configuration interface for a LoRaWAN device. At the top, there are two tabs: 'Device' (selected) and 'Network'. Below the tabs, there are two radio buttons: 'LoRaWAN' (selected) and 'D2D'. The 'Device EUI' field contains the value '24E124460F345074'. The 'APP EUI' field contains '24e124c0002a0001'. The '* Application Port' field is set to '85'. The 'LoRaWAN Version' dropdown menu is set to 'V1.0.3'. The 'Work Mode' dropdown menu is set to 'Class A'. The 'Confirmed Mode' toggle switch is turned on. At the bottom, the 'Join Type' dropdown menu is set to 'OTAA', with 'Read' and 'Write' buttons below it.

3. From the **Join Type** selection box, select **OTAA** or **ABP** as needed.



Note:

OTAA is required if you connect the device to the [Milesight Development Platform](#).

4. Configure **Join Type** related parameters as needed. Use default values unless otherwise specified.

- If **OTAA** is selected, configure **Application Key** and **Rejoin Mode** as needed. For details, refer to the following table.

Parameter	Description
Application Key	<p>Appkey for OTAA mode. Default: Device EUI + Device EUI (since Q4 of 2025).</p> <p>Example: 24e124123456789024e1241234567890.</p> <p>Default value of earlier devices: 5572404C696E6B4C6F52613230313823.</p> <div style="border: 1px solid #ccc; border-radius: 10px; background-color: #e6f2ff; padding: 10px; margin-top: 10px;"> <p> Tip: Contact sales before purchase if you need random App keys.</p> </div>
Rejoin Mode	<p>Rejoin mode for OTAA mode.</p> <p>Reporting interval ≤ 35 minutes: The device sends a specific number of LinkCheckReq MAC packets at each reporting interval or at every other reporting interval to validate connectivity.</p> <p>Reporting interval > 35 minutes: The device sends a specific number of LinkCheckReq MAC packets at each reporting interval to validate connectivity.</p> <p>If there is no response, the device will re-join the network.</p> <p>When Rejoin Mode is enabled, enter a number in the Set the number of detection signals sent text box. The actual sending number is the configured number +1.</p>

- If **ABP** is selected, configure **Network Session Key**, **Application Session Key** and **Device Address** as needed. For details, refer to the following table.

Parameter	Description
Network Session Key	<p>Nwkskey for ABP mode. Default: 5572404C696E6B4C6F52613230313823.</p>

Parameter	Description
Application Session Key	Appskey for ABP mode. Default: 5572404C696E6B4C6F52613230313823.
Device Address	DevAddr for ABP mode. Default: 5 th to 12 th digits of SN.

5. Select a frequency from the **Support Frequency** selection box as needed. The frequency must be the same as that of the gateway configured on the gateway web GUI.
6. If **CN470**, **US915** or **AU915** is selected, enter the index of the channel that you want to enable in the **Enable Channel Index** input box. The channel indexes should be separated by commas.

Examples:

- 1, 40: Enables channel 1 and channel 40
- 1-40: Enables channel 1 to channel 40
- 1-40, 60: Enables channel 1 to channel 40 and channel 60
- Null: Indicates that all channels are disabled

7. Click **Write** and put the NFC detection area of the phone close to the NFC antenna of device. If the configuration succeeds, the following page is displayed.



Write successfully!

Configure Basic Network Parameters

This section describes how to configure the LoRaWAN[®] parameters of the device. You can use default values unless otherwise specified.

Steps:

1. On the homepage of ToolBox, click **Setting** to enter the **Setting** page.
2. Click **Network**. The **Network** page is displayed, see the following figure.

3. Configure the following parameter as needed. Use default values unless otherwise specified. For a description of the parameters, refer to the following table.

Parameter	Description
Device EUI	Unique ID of the device labelled on the device housing.

Parameter	Description
	 Tip: For bulk deployments, contact sales to request the device EUI list.
App EUI	The default App EUI (join EUI) is 24E124C0002A0001.
Application Port	Port used for sending and receiving data. Default: 85 .
LoRaWAN [®] Version	Options: V1.0.2, V1.0.3 .
Work Mode	Fixed value: Class A .
Confirmed Mode	If it is enabled, the device retransmits data when the device does not receive ACK packet from the network server.
Join Type	Refer to Configure the Joining Type and the Frequency .
Supported Frequency	Refer to Configure the Joining Type and the Frequency .
ADR Mode	Enables the network server to adjust the spreading factor, the bandwidth and the transmission power to optimize data rates, airtime and energy consumption in the network.
Spreading Factor	If ADR mode is disabled, the device sends uplink data using this spreading factor. A higher spreading factor increases transmission range but reduces data rate and increases power consumption. This parameter varies with Supported Frequency .
Tx Power	Defined by the LoRa Alliance. Specifies the strength of the radio signal transmitted by the device.
RX2 Data Rate	RX2 data rate to receive downlinks or send D2D messages.
RX2 Frequency	RX2 frequency to receive downlinks or send D2D messages. Unit: Hz

4. Click **Write** and put the NFC detection area of the phone close to the NFC antenna of device. If the configuration succeeds, the following page is displayed.



Write successfully!

Configure the Milesight D2D Parameters

Milesight D2D protocol is developed by Milesight and used for setting up transmission among Milesight devices without gateway, which is able to reduce the latency and achieve the quick control.

D2D Data Transmission Settings

TS30x supports sending sensor data to other Milesight devices directly via Milesight D2D. Before using this feature, please ensure that you have one or more Milesight sensors **which support D2D Data Receiving feature**.



Note:

Data receiving device only supports receiving data from the left channel (CH1).

Steps:

1. On the homepage of ToolBox, click **Setting** to enter the **Setting** page.
2. Click **Network**. Configure the **RX2 Data Rate** and **RX2 Frequency** to be the same as the data receiving devices.
3. Click **D2D**, the **D2D** page is displayed, see the following figure.

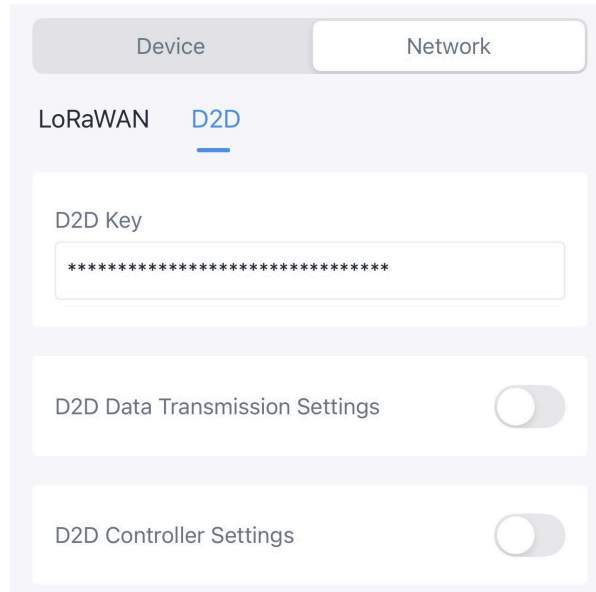

4. Set the D2D key to be the same as the Milesight sensors. (Default D2D Key: 5572404C696E6B4C6F52613230313823)
5. Enable the **D2D Data Transmission Settings**.

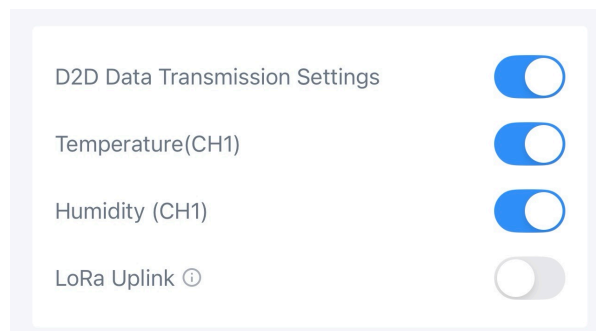

6. Enable the **Temperature** and **Humidity** data transmission as needed.



Note:

If **LoRa Uplink** is enabled, a LoRaWAN[®] uplink packet that contains corresponding alarm status will be sent to gateway after the Milesight D2D command packet. Otherwise, the packet will not send to LoRaWAN[®] gateway.

7. Click **Write** and put the NFC detection area of the phone close to the NFC antenna of device. If the configuration succeeds, the following page is displayed.



Write successfully!

Milesight D2D Controller

The device is able to work as a D2D controller device to send commands to trigger D2D agent devices when the threshold alarm is triggered or dismissed.

Steps:

1. On the homepage of ToolBox, click **Setting** to enter the **Setting** page.
2. Click **Network**. Configure the **RX2 Data Rate** and **RX2 Frequency** to be the same as the settings of Milesight D2D agent devices.
3. Click **D2D**, the **D2D** page is displayed, see the following figure.

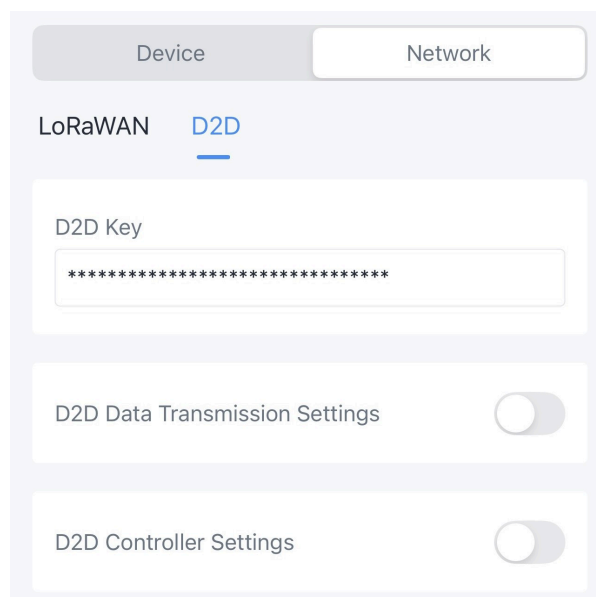

4. Define a unique D2D key to be the same as D2D agent devices. (Default D2D Key: 5572404C696E6B4C6F52613230313823)
5. Enable **D2D Controller Settings**, and enable one of statuses and configure 2-byte hexadecimal Milesight D2D command.



Note:

If **LoRa Uplink** is enabled, a LoRaWAN[®] uplink packet that contains corresponding alarm status will be sent to gateway after the Milesight D2D command packet. Otherwise, the packet will not send to LoRaWAN[®] gateway.

6. Click **Write** and put the NFC detection area of the phone close to the NFC antenna of device. If the configuration succeeds, the following page is displayed.



Write successfully!

Example: When the door is opened, the device will send command ff01 to D2D agent devices.

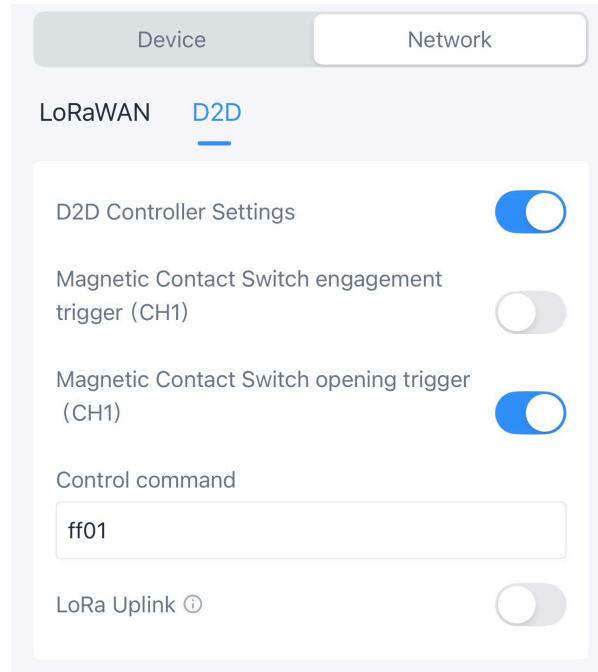

Configure the Device Parameters

This section describes how to configure the device.

Change the Device Password

It is recommended to change the device password upon initial configuration for security purposes. This section describes how to change the password.

Steps:

1. On the homepage, click **Setting** to enter the **Setting** page.
2. In the **General** page, enable **Change Password**.
3. In the **New Password** text box, enter the new password as prompted.
4. In the **Confirm Password** text box, enter the password again.
5. Click **Write** in the lower right corner.
6. Put the NFC detection area of the phone close to the NFC antenna of device.
7. If the password was changed successfully, the following page is displayed.



Write successfully!

Configure Basic Device Parameters

This section describes how to configure the basic parameters of the device, which includes:

- Reporting interval
- Temperature Unit
- Button Lock
- Data Storage
- Data Retransmission
- 24-Hour Clock
- Time Zone
- Daylight Saving Time
- Device password

Steps:

1. On the homepage of ToolBox, click **Setting** to enter the **Setting** page.
2. In the **General** page, configure the following device parameters as needed.

Parameter	Description
Reporting interval	Reporting interval of transmitting data to the network server. Range: 10~1440min, Default: 10min.
Temperature Unit	Change the temperature unit displayed on the ToolBox and the LCD screen.

Parameter	Description
	 Note: <ul style="list-style-type: none"> a. The temperature unit in the reporting package is fixed as Celsius(°C). b. Please modify the threshold settings if the unit is changed.
Button Lock	After it is enabled, the function of being locked through button operations is not allowed. Options: Turn Off and Collect and Report .
Data Storage	Disables or enables data storage. For details, refer to Configure the Data Storage&Retransmission .
Data Re-transmission	Disables or enables data retransmission. For details, refer to Configure the Data Storage&Retransmission .
24-Hour Clock	Click to change the time displayed on the screen. ToolBox allows switching between 12-hour and 24-hour formats.
Time Zone	Select the UTC time zone. When you click Sync button of ToolBox App to sync time, the device will also sync the time zone from smart phone automatically.
Daylight Saving Time	<p>Enable or disable Daylight Saving Time (DST).</p> <p>Start Time: the start time of DST time range.</p> <p>End Time: the end time of DST time range.</p> <p>DST Bias: the DST time will be faster according to this bias.</p>
Device password	Change the password for ToolBox App to write this device.

3. Click **Write** in the lower right corner.

4. Put the NFC detection area of the phone close to the NFC antenna of device. If the configuration succeeds, the following page is displayed.



Write successfully!

Configure the Data Storage & Retransmission

The device supports data storage and data retransmission to ensure data integrity. This section describes how to configure data storage and retransmission.

Export the Local Data

The device supports storing up to 10,000 historical records locally. Data will continue to be saved even when the network is de-activated. Since the ToolBox data export time range is limited to 14 days, you can export the complete data in segments if the time range exceeds this limit.

Export as csv file

Steps:

1. [Sync the time](#) to ensure the data is stored in correct time.
2. On the homepage of ToolBox, click **Setting** to enter the **Setting** page.
3. Enable **Data Storage**.
4. Return to the homepage and click **Maintenance** in the lower right corner.
5. Click **Export**, select the data time range and click **Save** to export data.

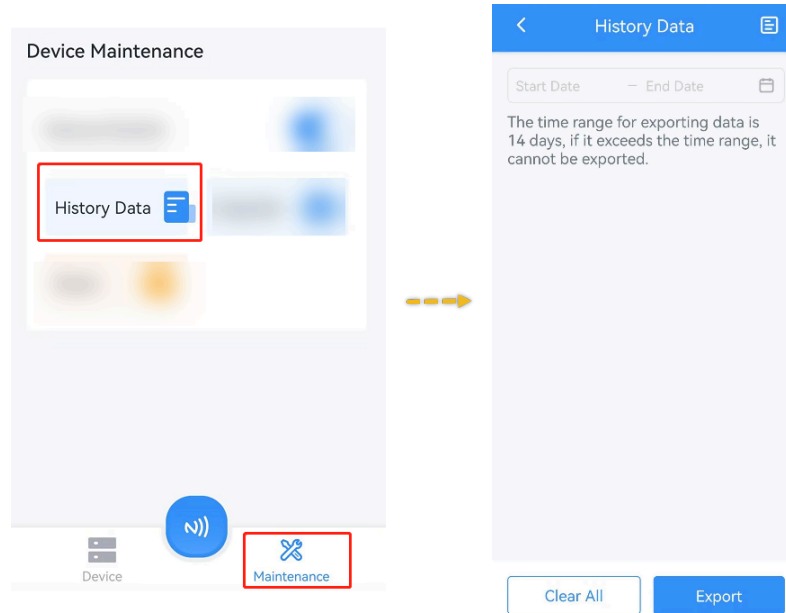

Export as PDF file

TS30x supports data plug-and-play by USB port, which exports encrypted & anti-tampering PDF data. The USB data export without driver installation. The PDF file only stores temperature and humidity data, not door sensor switch data.

Steps:

1. [Sync the time](#) to ensure the data is stored in correct time.
2. Remove the USB waterproof plug from the bottom of the device.
3. Connect it to the computer via a type-C USB cable. The PC will display a disk folder from device to display the stored data which is automatically exported as an encrypted document in PDF format.



Note:

- The disk folder from device is only used to export PDF file and is not allowed to put other files.
- The PDF file is not allowed to be edited to prevent tampering-- FDA CFR 21B regulatory requirements.

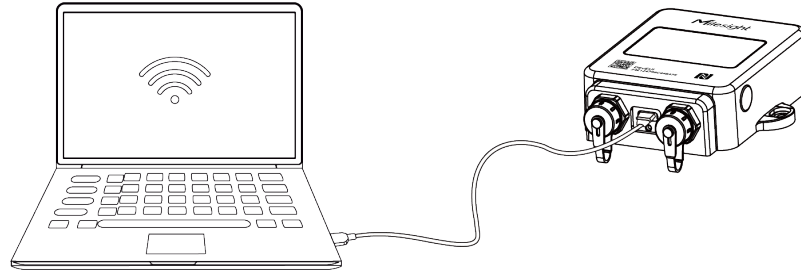

4. Copy the PDF file to your PC's another disk folder to get the data.

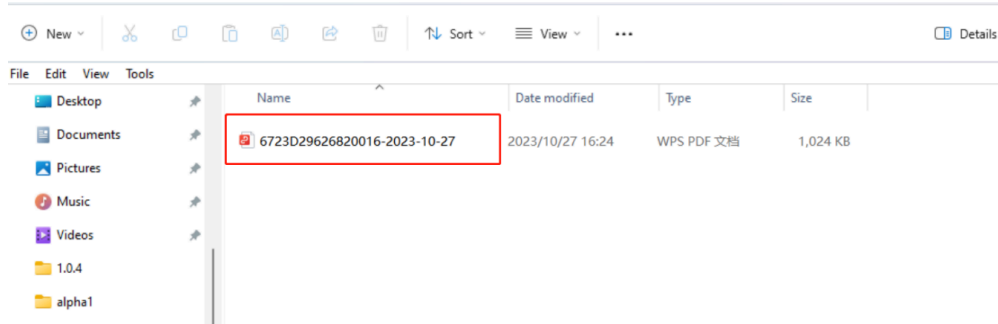

Enable Data Retransmission

Data retransmission allows the network server receives all data, even after temporary network outages. The reported format of retransmission data will include timestamps and is different from periodic report data.

Steps:

1. On the homepage, click **Setting** to enter the **Setting** page.
2. Enable **Data Storage** and **Data Retransmission**.
3. Click **Network** to enter the **Network** page.
4. Set Join Type to **OTAA**, enable Rejoin Mode and set the number of packets sent.
5. Click **Write** in the lower right corner.
6. Put the NFC detection area of the phone close to the NFC antenna of device.

7. If the configuration succeeds, the following page is displayed.



Write successfully!



Note:

1. Data retransmission increases the uplink traffic and shortens the battery life.
2. If the device reboots or loses power during data retransmission, it restarts and resends the entire retransmission dataset after reconnecting to the network.
3. If a new network disconnection occurs during an ongoing retransmission, only the data logged during this latest outage will be sent upon reconnection.
4. The default report data retransmission interval is 600s, this can be changed via downlink command.

Query Historical Data

The device supports querying historical data for a specific time range via downlink command. The retransmission data format includes timestamps and differs from the periodic report format. For details, refer to [Historical Data Query Commands](#).

Configure Calibration Parameters

This section describes how to configure calibration. Set the calibration value, the device will add calibration value to the current temperature value, then display and report the final value.

Steps:

1. On the homepage of ToolBox, click **Setting** to enter the **Setting** page.
2. Click **Calibration**. The following page is displayed.

3. Enable **Temperature**. Enter a value in the **Calibration Value** text box. The following page is displayed.

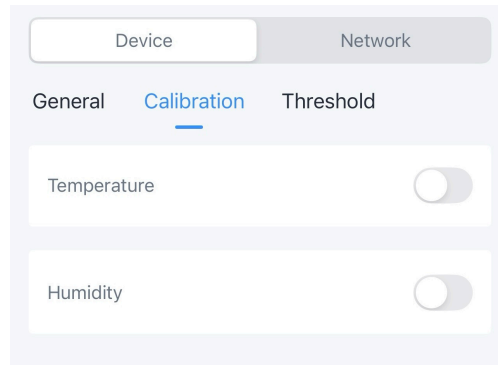

4. Enable **Temperature** or **Humidity** . Enter a value in the **Calibration Value** text box. The following page is displayed.



5. Click **Write** in the lower right corner.

- Put the NFC detection area of the phone close to the NFC antenna of the device. If the configuration succeeds, the following page is displayed.



Write successfully!

Configure the Threshold Parameters

The device supports threshold alarms, shift threshold (change) alarms and magnetic contact switch alarm. This section describes how to configure this threshold parameters.



Note:

when you change the temperature unit, please re-configure the threshold.

Threshold Alarm

The device support to collect temperature and humidity values at a configured interval. If the values reaches the configured threshold, the device immediately uploads the current data.

Only after the previous alarm is cleared and the threshold is re-triggered, the device sends a new alarm.

Steps:

- On the homepage of ToolBox, click **Setting** to enter the **Setting** page.
- Click **Threshold** and enable **Temperature** or **Humidity**.

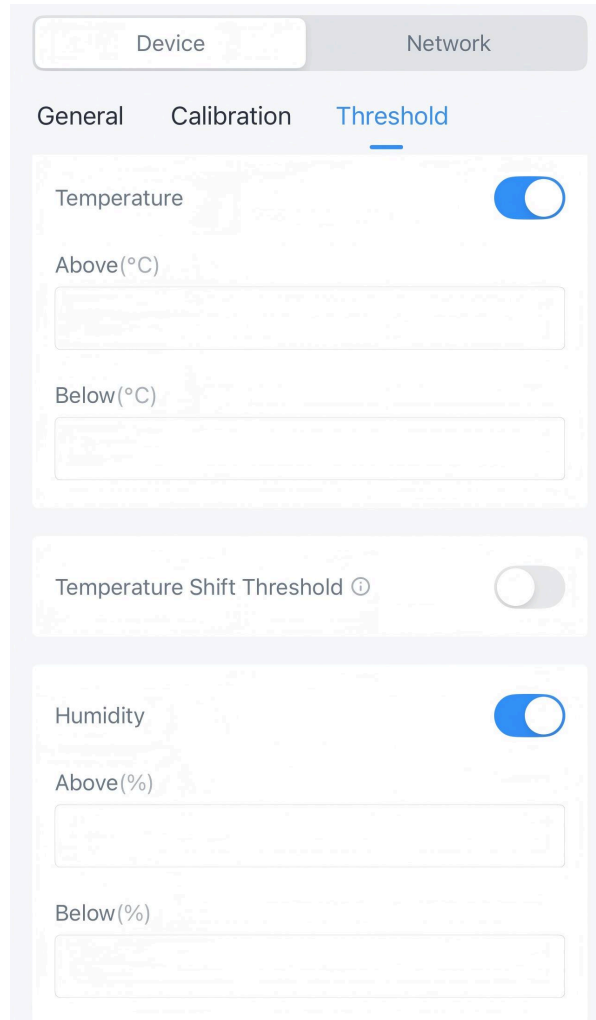

3. Configure the following threshold parameters.

Parameters	Description
Above/Below	Temperature or humidity threshold.
Collecting Interval	The interval to detect temperature or humidity value, this should be smaller than or equal to the reporting interval. Default: 1mins.
Alarm Reporting Times	Alarm packet report times after threshold alarm triggers. Default is 1.
Alarm Dismiss Report	When enabled, the device reports the current value to signal that the alarm has cleared once the reading returns to within the threshold range.

4. Click **Write** in the lower right corner.
5. Put the NFC detection area of the phone close to the NFC antenna of the device. If the configuration succeeds, the following page is displayed.



Write successfully!

Shift Threshold Alarm

The device supports to report an alarm packet when the absolute value of the difference between the current value and the last collected value exceeds the threshold value.

Steps:

1. On the homepage of ToolBox, click **Setting** to enter the **Setting** page.
2. Click **Threshold** and enable **Temperature Shift Threshold** or **Humidity Shift Threshold**.

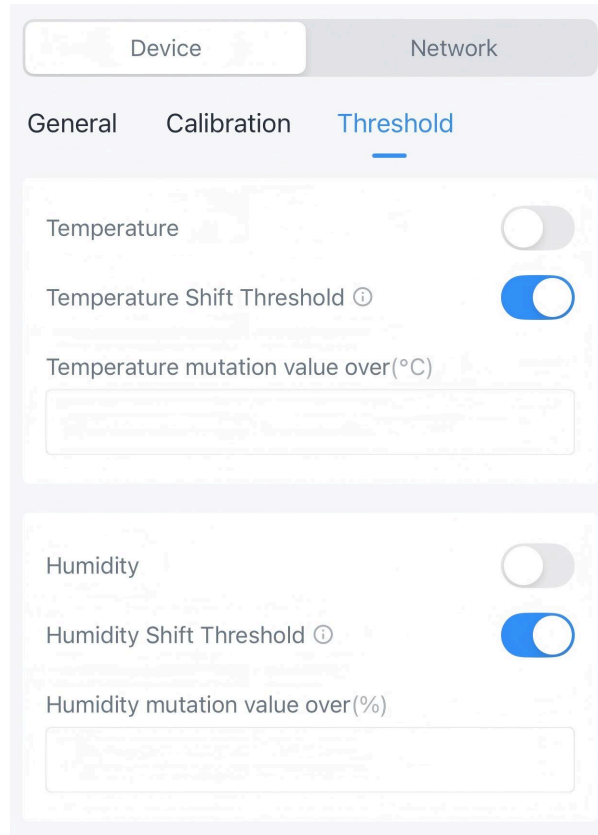

3. Configure the following threshold parameters.

Parameters	Description
Temperature/Humidity mutation value over	When enabled, the device triggers an alarm if the absolute change in value exceeds the set threshold.
Collecting Interval	The interval to detect temperature or humidity value, this should be smaller than or equal to the reporting interval. Default: 1 min.

4. Click **Write** in the lower right corner.

- Put the NFC detection area of the phone close to the NFC antenna of the device. If the configuration succeeds, the following page is displayed.



Write successfully!

Magnetic Contact Switch Alarm Delay

The device supports reporting an alarm packet when the magnetic contact switch state is changed. When the **Magnetiuc Contact Switch alarm delay** is enabled, the alarm packet will only be reported if the door remains open longer than the configured threshold.

Steps:

- On the homepage of ToolBox, click **Setting** to enter the **Setting** page.
- Click **Threshold** and enable **Magnetic Contact Switch alarm delay**.
- Enter a value in the **Delayed alarm time** box as needed.

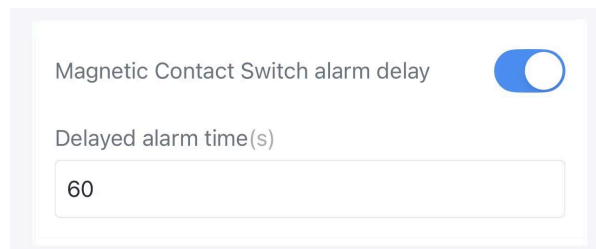

Magnetic Contact Switch alarm delay

Delayed alarm time(s)

60

- Click **Write** in the lower right corner.

5. Put the NFC detection area of the phone close to the NFC antenna of the device. If the configuration succeeds, the following page is displayed.



Write successfully!

Maintain the Device

This section describes how to maintain the device.

Upgrade

This chapter describes how to upgrade the device. Any operation on ToolBox is not allowed during upgrading, otherwise the upgrading will be interrupted, or even the device will break down.

Steps:

1. Download firmware from [Milesight official website](#) and save it to the smart phone.
2. Launch ToolBox and click **Maintenance** in the lower right corner of the homepage.
3. Click **Upgrade** to import firmware and upgrade the device.

4. Click **Upgrade** to upgrade the device.

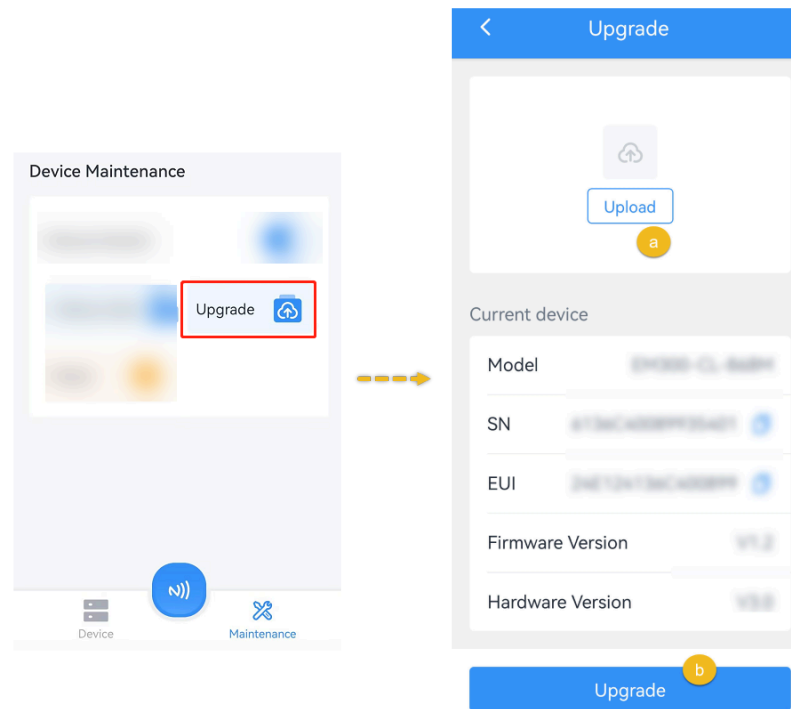

Configure a Template for Configuration Backup

This device supports configuration backup, which enables quick and easy batch configuration. This function only applies for devices of the same model.

Steps:

Set a Template

Steps:

1. Launch ToolBox App, attach the NFC area of smartphone to the device to read the configuration.
2. Edit the configuration as required, click **Set Template** to save current configuration as a template to the ToolBox App.
3. Click **Confirm** to save the current configuration as a template.

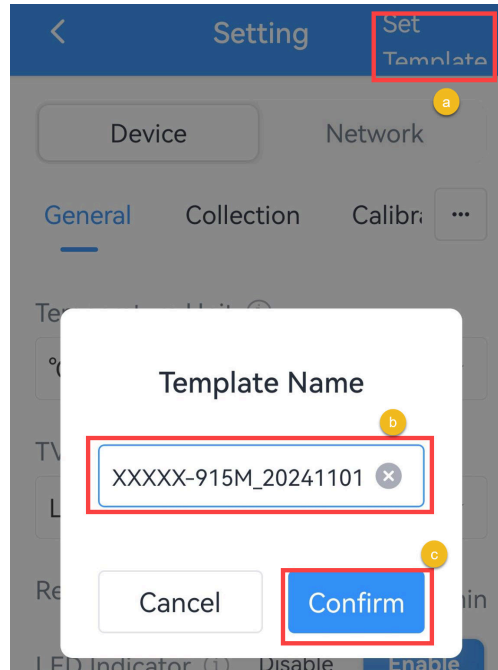

4. If the save is successfully, the following page is displayed.

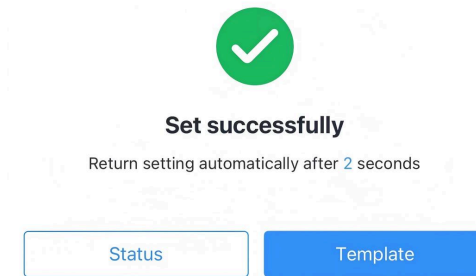

Write the template configuration to the target device

Steps:

1. Go to **Device > Template** page.



2. Click the saved template. Do not select the template.

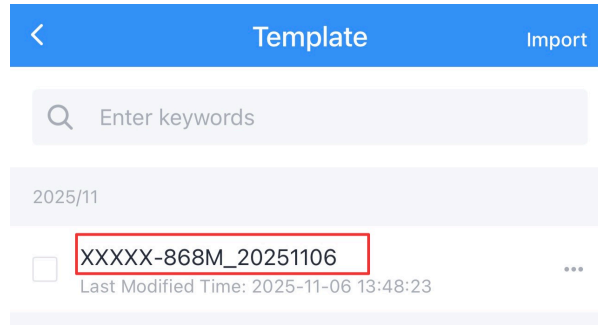

3. In the displayed page, click **Write** in the bottom and put the NFC detection area of the phone close to the NFC antenna of the target device. If the configuration is written to the target device, the following page is displayed.



Write successfully!

Export and Delete a Template

Steps:

1. Select the checkbox of the target template as shown in the following figure.

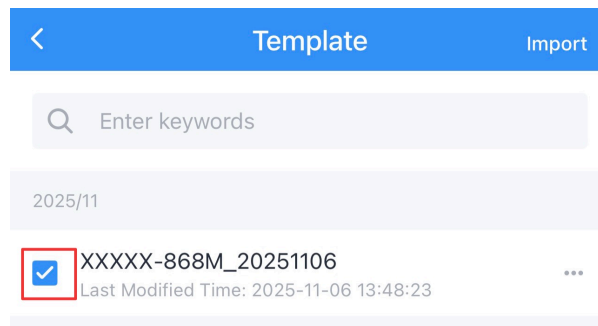

2. Click **Export** to export this template as a JSON format file and save it to the smart phone.
3. Click **Delete** and Confirm to delete this template from ToolBox.

Reset the Device

This section describes how to reset the device in ToolBox. Additionally, the device supports hardware reset. See [Button Descriptions](#) for details.

Steps:

1. On the homepage of ToolBox, click **Maintenance** in the lower right corner. The **Maintenance** page is displayed, see the following figure.

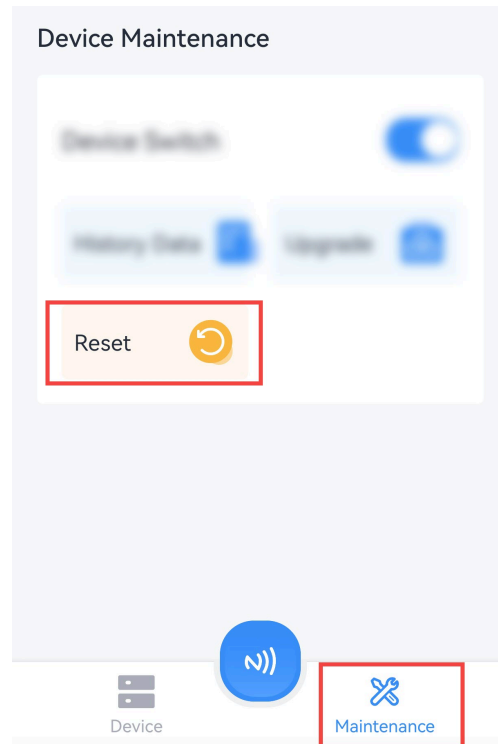

2. Click **Reset**.
3. In the displayed dialog box, click **Confirm**.

4. Put the NFC detection area of the phone close to the NFC antenna of the device. If the device is successfully reset, the following page is displayed.



Write successfully!

Chapter 5. Uplink Packets and Downlink Commands

The device uses the standard Mulesight IoT payload format based on IPSO. This chapter describes the uplink data packets and downlink commands supported by the device. They are all structured in the following format, the Data field should follow **little endian**:

Channel 1	Type 1	Data 1	Channel 2	Type 2	Data 2	Channel 3	...
1 Byte	1 Byte	N Bytes	1 Byte	1 Byte	N Bytes	1 Byte	...

All explanations and examples in this document are based on the HEX format. For all the Mulesight IoT decoder examples, refer to the files available on <https://github.com/Mulesight-IoT/SensorDecoders>.

Uplink Packets

This section describes the uplink packets reported by the device.

Basic Information Packet

When joining the network, the device reports a packet containing the basic device information to the gateway.



Note:

CH1=Left channel of TS301/TS302, CH2=Right channel of TS302.

Packet description:

Item	Channel	Type	Byte	Description
Power On	ff	0b	1	Device is on
Protocol Version	ff	01	1	Example: 01=V1
Hardware Version	ff	09	2	Example: 03 10 = V3.1
Software Version	ff	0a	2	Example: 03 01 = V3.1
Device Type	ff	0f	1	00: Class A, 01: Class B, 02: Class C, 03: Class C to B
Serial Number	ff	16	8	16 digits
TSL Version	ff	ff	2	Example: 01 00=>V1.0

Item	Channel	Type	Byte	Description
Reset Report	ff	fe	1	ff, report after reset to factory default

Example:

ff0bff ff0101 ffefff ff166508f12012660016 ff090200 ff0a0101 ff0f00 ffff0100		
Channel	Type	Value
ff	0b	ff
ff	01	Protocol Version: 01=V1
ff	16	SN: 6508f12012660016
ff	09	Hardware Version: 0200=V2.0
ff	0a	Software Version: 0101=V1.1
ff	0f	00: Class A
ff	ff	TSL Version: 0100=V1.0

Periodically Reported Data Packet

The device reports a sensor data packet at a configured interval.

Packet description:

Item	Channel	Type	Byte	Description
Battery Level	01	75	1	UINT8, Unit: %
Temperature (CH1)	03	67	2	INT16/10, Unit: °C, Resolution: 0.1°C
Humidity (CH1)	03	9a	2	UINT16/10, Unit: %RH, Resolution: 0.1%RH
Magnet Switch (CH1)	03	00	1	UINT8, 00: closed, 01: open
Temperature (CH2)	04	67	2	INT16/10, Unit: °C
Humidity (CH2)	04	9a	2	UINT16/10, Unit: %RH, Resolution: 0.1%RH
Magnet Switch (CH2)	04	00	2	UINT8, 00: closed, 01: open

Example:

017564 0367f900 039a6602 040001		
Channel	Type	Value
01	75	Battery Level: 64 => 100%
03	67	Temperature: f9 00 => 00 f9 =249/10=24.9°C
03	9a	Humidity: 66 02=>02 66=614/10=61.4%RH
04	00	01 => Magnet switch open

Probe ID Report

When the device detects a probe replacement, it reports a Probe ID data packet.

Packet description:

Channel	Type	Byte	Description
ff	a0	9	<p>Byte 1: Channel</p> <ul style="list-style-type: none"> • Bit 3-0: <ul style="list-style-type: none"> ◦ 0 = CH1 ◦ 1 = CH2 • Bit 7-4: <ul style="list-style-type: none"> ◦ 1 = PT100 sensor ◦ 2 = TH sensor ◦ 3 = DS18B20 sensor ◦ 4 = Magnet switch sensor <p>Byte 2-9:</p> <ul style="list-style-type: none"> • PT100: FFFFFFFFFFFFFFFF • TH: 00000000+Probe ID • DS18B20: Probe ID • Magnet switch: FFFFFFFFFFFFFFFF

Channel	Type	Byte	Description
			 Note: When probe ID is reported as all "F", it means acquisition failure.

Example:

ff a0 12 00 00 00 00 ac 7c 11 43		
Channel	Type	Value
ff	a0	12=> CH2 probe: TH sensor, ID: ac 7c 11 43

Alarm Report

The device reports the following types of alarm packets.

Packet description:

Item	Channel	Type	Byte	Description
Temperature Threshold Alarm (CH1)	83	67	3	<p>Byte 1-2: Temperature, INT16/10, Unit: °C</p> <p>Byte 3: Alarm Status</p> <ul style="list-style-type: none"> • 00 = Above (max. threshold) alarm • 01 = Above dismiss • 02 = Below (min. threshold) alarm • 03 = Below dismiss • 04 = Within alarm • 05 = Within dismiss • 06 = Beyond alarm • 07 = Beyond dismiss
Humidity Threshold Alarm (CH1)	83	9a	3	<p>Byte 1-2: Humidity, INT16/10, Unit: %RH</p> <p>Byte 3: Alarm Status</p>

Item	Channel	Type	Byte	Description
				<ul style="list-style-type: none"> • 00 = Above (max. threshold) alarm • 01 = Above dismiss • 02 = Below (min. threshold) alarm • 03 = Below dismiss • 04 = Within alarm • 05 = Within dismiss • 06 = Beyond alarm • 07 = Beyond dismiss
Temperature Threshold Alarm (CH2)	84	67	3	<p>Byte 1-2: Temperature, INT16/10, Unit: °C</p> <p>Byte 3: Alarm Status</p> <ul style="list-style-type: none"> • 00 = Above (max. threshold) alarm • 01 = Above dismiss • 02 = Below (min. threshold) alarm • 03 = Below dismiss • 04 = Within alarm • 05 = Within dismiss • 06 = Beyond alarm • 07 = Beyond dismiss
Humidity Threshold Alarm (CH2)	84	9a	3	<p>Byte 1-2: Humidity, INT16/10, Unit: %RH</p> <p>Byte 3: Alarm Status</p> <ul style="list-style-type: none"> • 00 = Above (max. threshold) alarm • 01 = Above dismiss • 02 = Below (min. threshold) alarm • 03 = Below dismiss • 04 = Within alarm • 05 = Within dismiss • 06 = Beyond alarm • 07 = Beyond dismiss

Item	Channel	Type	Byte	Description
Temperature Shift Alarm (CH1)	93	67	5	<p>Byte 1-2: Temperature, INT16/10, Unit: °C</p> <p>Byte 3-4: Shift temperature, INT16/10, Unit: °C</p> <p>Byte 5: 00</p>
Humidity Shift Alarm (CH1)	93	9a	5	<p>Byte 1-2: Humidity, INT16/10, Unit: %RH</p> <p>Bit 3-4: Shift humidity, INT16/10, Unit: %RH</p> <p>Byte 5: 00</p>
Temperature Shift Alarm (CH2)	94	67	5	<p>Byte 1-2: Temperature, INT16/10, Unit: °C</p> <p>Byte 3-4: Shift temperature, INT16/10, Unit: °C</p> <p>Byte 5: 00</p>
Humidity Shift Alarm (CH2)	94	9a	5	<p>Byte 1-2: Humidity, INT16/10, Unit: %RH</p> <p>Byte 3-4: Shift humidity, INT16/10, Unit: %RH</p> <p>Byte 5: 00</p>
Temperature Overrange Alarm (CH1)	b3	67	3	<ul style="list-style-type: none"> • 00 = Collection error • 01 = Over-range • 02 = Under-range
Humidity Overrange Alarm (CH1)	b3	9a	3	<ul style="list-style-type: none"> • 00 = Collection error • 01 = Over-range • 02 = Under-range
Temperature Overrange Alarm (CH2)	b4	67	3	<ul style="list-style-type: none"> • 00 = Collection error • 01 = Over-range • 02 = Under-range

Item	Channel	Type	Byte	Description
Humidity Over-range Alarm (CH2)	b4	9a	3	<ul style="list-style-type: none"> • 00 = Collection error • 01 = Over-range • 02 = Under-range

Example 1:

Temperature threshold alarm: reports a alarm packet when the temperature below the threshold.

8367140102		
Channel	Type	Value
83	67	14 01 => 01 14 => 276/10 = 27.6°C 02 => Below (min. threshold) alarm

Example 2:

Humidity shift alarm: reports a alarm packet when the humidity shift alarm is trigger.

939a5202010000		
Channel	Type	Value
93	9a	52 02 => 02 52 => 594/10 = 59.4 %RH 01 00=> 00 01 = 1/10=0.1%RH 00 = Humidity shift alarm

Downlink Commands

Downlink commands can be used for remote control of device through a network server. The downlink port (application port) is 85 by default and can be configured through ToolBox.

Commands for General Setting

The device supports multiple commands for general setting.

Command description:

Item	Channel	Type	Byte	Description
Reboot	ff	10	1	ff
Report Interval	ff	8e	3	Byte 1: 00 Byte 2-3: interval time, UINT16, unit: min, range: 1-1440
Collect Interval	ff	02	2	UINT16, Unit: s
Data Storage	ff	68	1	00: Disable, 01: Enable
Data Re-transmission	ff	69	1	00: Disable, 01: Enable
Data Retransmission Interval	ff	6a	3	Byte 1: 00 Byte 2-3: UINT16, Unit: s, Range: 30~1200, Default: 600
Temperature Unit	ff	eb	1	00=°C, 01=°F
Button Lock	f9	69	1	<ul style="list-style-type: none"> • 01: Lock turn off • 02: Lock collect and report • 03: Lock turn off, collect and report
Clear History Data	ff	27	1	01
Enquiry Periodic Report	ff	28	1	ff
Screen	ff	2d	1	<ul style="list-style-type: none"> • 00: Disable • 01: Enable • ff: Enable when temperature sensor is connected (default)

Item	Channel	Type	Byte	Description
Enquire the Probe ID	f9	31	1	<ul style="list-style-type: none"> • 00: CH1 • 01: CH2 • 02: CH1 and CH2

Example 1:

Reboot the device.

ff10ff

Example 2:

Enable the button lock, the device cannot be turned off, collected and reported by power button.

f96903		
Channel	Type	Value
f9	69	03 = Lock turn off, collection and report

Commands for Time Settings

The device supports multiple commands for time setting.

Command description:

Item	Channel	Type	Byte	Description
Sync Time	ff	4a	1	00
UTC Time Zone	ff	bd	2	INT16/60
Time Type	ff	e9	1	00: 12-hours clock, 01: 24-hours clock
Daylight Saving Time	f9	72	9	<p>Byte 1:</p> <ul style="list-style-type: none"> • Bit 7: 0=disable,1=enable • Bit 6-0: DST bias, unit: min, range: 1-120

Item	Channel	Type	Byte	Description				
				<p>Byte 2-5: Start time, Month (1B)+Week&Day (1B) + Minute Time (2B)</p> <p>Byte 6-9: End time</p> <p>Week&Day:</p> <table border="1" style="margin-left: 40px;"> <thead> <tr> <th>Bit7-4</th> <th>Bit3-0</th> </tr> </thead> <tbody> <tr> <td>Week number, range: 1-5</td> <td>Weekday, range: 1-7</td> </tr> </tbody> </table>	Bit7-4	Bit3-0	Week number, range: 1-5	Weekday, range: 1-7
Bit7-4	Bit3-0							
Week number, range: 1-5	Weekday, range: 1-7							

Example:

Set DST time: start time is second Sunday 1:00 of March, end time is second Sunday 1:00 of October, and bias is 1h (60 minutes).

f9 72 bc 03 27 3c00 0a 27 3c00		
Channel	Type	Value
f9	72	<p>bc=1011 1100=> enable daylight saving time, DST bias: 60 mins</p> <p>Start time: 03=>March, 27=>second Sunday, 3c 00 =>00 3c=60 minutes =1:00</p> <p>End time: 0a=>10=October, 27=>second Sunday(7), 3c 00 =>00 3c=60 minutes =1:00</p>

Commands for Calibration Settings

Channel	Type	Byte	Description
ff	ea	3	<p>Byte 1:</p> <ul style="list-style-type: none"> • 00 = disable CH1 temperature • 80 = enable CH1 temperature • 01 = disable CH2 temperature • 81 = enable CH2 temperature • 02 = disable CH1 humidity

Channel	Type	Byte	Description
			<ul style="list-style-type: none"> • 82= enable CH1 humidity • 03 = disable CH2 humidity • 83 = enable CH2 humidity <p>Byte 2-3: calibration value, INT16/10, range: -2000-10000°C or -1000-1000%RH.</p>

Example:

Enable temperature calibration for CH1 and set the calibration value to -200°C.

feea8030f8		
Channel	Type	Value
ff	ea	80 = enable CH1 temperature, 30 f8=>f8 30=-2000/10=-200 °C

Commands for Threshold Settings

Item	Channel	Type	Byte	Description
Alarm Reporting	ff	7e	5	<p>Byte 1: 00</p> <p>Byte 2-3: Reporting interval, UINT16, range: 1-1440, Unit: min</p> <p>Byte 4-5: Reporting times, UINT16, range: 1-65535</p>
Alarm Dismiss Report	ff	f5	1	00: Disable, 01: Enable
Threshold Alarm	ff	06	9	<p>Byte 1:</p> <ul style="list-style-type: none"> • Bit 2~Bit 0: <ul style="list-style-type: none"> ◦ 000=Disable ◦ 001=Below ◦ 010=Above ◦ 011=Within

Item	Channel	Type	Byte	Description
				<ul style="list-style-type: none"> ◦ 100=Below or above ◦ 101=Shift change • Bit 5~Bit 3: <ul style="list-style-type: none"> ◦ 000=Temperature Threshold of CH1 ◦ 001=Temperature Threshold of CH2 ◦ 010=Temperature Shift Threshold of CH1 ◦ 011=Temperature Shift Threshold of CH2 ◦ 100=Humidity Threshold of CH1 ◦ 101=Humidity Threshold of CH2 ◦ 110=Humidity Shift Threshold of CH1 ◦ 111=Humidity Shift Threshold of CH2 • Bit 6: <ul style="list-style-type: none"> ◦ 0=Disable the alarm threshold ◦ 1=Enable the alarm threshold • Bit7: 0 <p>Byte 2-3: min. threshold, UINT16/10. Temperature range: -30000-30000, humidity range: 0-1000.</p> <p>Byte 4-5: max. threshold, UINT16/10. Temperature range: -30000-30000, humidity range: 0-1000, shift change range: 1-1000.</p> <p>Byte 6-9: 0000</p>
Magnet-ic Switch Delayed Alarm Time	f9	9a	2	<p>0000: Disabled</p> <p>UINT16, Unit: s, range: 4-65535.</p>

Example 1:

Enable the temperature threshold alarm for CH1 and set the alarm threshold as over 37°C.

ff06 42 0000 7201 0000 0000		
Channel	Type	Value
ff	06	CTRL: 42 = 0100 0010 010 = Above 000 = CH1 Temperature Threshold 1 = Enable the Threshold Alarm Max: 72 01 => 01 72 => 370/10 = 37°C

Example 2:

Enable the temperature shift threshold alarm for CH1 and set the threshold as over 1°C.

ff06 55 0000 0a00 0000 0000		
Channel	Type	Value
ff	06	CTRL: 55 = 0101 0101 101 = Shift change 010 = CH1 Temperature Shift Threshold 1 = Enable the Threshold Alarm Max: 0d00 => 00 0a => 10/10=1°C

Example 3:

Set threshold alarm interval to 10 minutes, alarm times to 3.

ff 7e 00 0a 00 03 00		
Channel	Type	Value
ff	7e	Reporting interval: 0a=10min

ff 7e 00 0a 00 03 00		
Channel	Type	Value
		Reporting times: 03 00=>00 03=3

Example 4:

Enable the magnetic contact switch alarm delay and set the delay time is 60s.

f9 9a 3c 00		
Channel	Type	Value
f9	9a	3c 00 => 003c = 60min

Commands for D2D Setting

The device supports multiple commands for D2D setting.

Command description:

Item	Channel	Type	Byte	Description
D2D Data Transmission Feature	f9	63	4	<p>Byte 1:</p> <ul style="list-style-type: none"> • 00=Disable the D2D data sending • 01=Enable the D2D data sending <p>Byte 2:</p> <ul style="list-style-type: none"> • 00=Disable the LoRa uplink • 01=Enable the LoRa uplink <p>Byte 3-4: For every bit: 0=Disable, 1=Enable</p> <ul style="list-style-type: none"> • Bit 0: CH1 temperature • Bit 1: CH1 humidity • Bit 3: CH2 temperature • Bit 4: CH2 humidity

Item	Channel	Type	Byte	Description
D2D Controller Feature	f9	66	1	00=Disable, 01=Enable
Milesight D2D Key	ff	35	4	First 16 digits, last 16 digits are fixed as 0
D2D Controller Condition	ff	96	8	<p>Byte 1:</p> <ul style="list-style-type: none"> • 01: CH1 temperature threshold triggered • 02: CH1 temperature threshold released • 03: CH1 temperature shift change • 04: CH1 humidity triggered • 05: CH1 humidity threshold released • 06: Ch1 humidity shift change • 07: CH1 door magnet closed • 08: CH1 door magnet opened • 09: CH2 temperature threshold triggered • 0a: CH2 temperature threshold released • 0b: CH2 temperature shift change • 0c: CH2 humidity triggered • 0d: CH2 humidity threshold released • 0e: CH2 humidity shift change • 0f: CH2 door magnet closed • 10: CH2 door magnet opened <p>Byte 2:</p> <ul style="list-style-type: none"> • 00=Disable the D2D controller • 01=Enable the D2D controller <p>Byte 3:</p> <ul style="list-style-type: none"> • 00=Disable the LoRa uplink • 01=Enable the LoRa uplink <p>Byte 4-5: Commands</p> <p>Byte 6-8: 000000</p>

Example 1:

Enable D2D data sending feature.

f963 01010f00		
Channel	Type	Value
f9	63	01=Enable the D2D data sending 01=Enable the LoRa uplink 0f00=>000f=>1111=Enable CH1 and CH2 temperature and humidity

Example 2:

ff96 040101 0100 0000000		
Channel	Type	Value
ff	96	04: CH1 humidity triggered 01=Enable the D2D controller 01=Enable the LoRa uplink Command: 0100

Commands for Configuration Query

The device supports multiple commands for querying its configuration.

Command format:

Item	Channel	Type	Data
Report Interval	f9	6f	01
Temperature Unit	f9	6f	03
Button Lock	f9	6f	04
CH1 Temperature Threshold	f9	6f	05
CH1 Humidity Threshold	f9	6f	06

Item	Channel	Type	Data
CH2 Temperature Threshold	f9	6f	07
CH2 Humidity Threshold	f9	6f	08
CH1 Temperature Shift Threshold	f9	6f	09
CH1 Humidity Shift Threshold	f9	6f	0a
CH2 Temperature Shift Threshold	f9	6f	0b
CH2 Humidity Shift Threshold	f9	6f	0c
Collect Interval	f9	6f	0d
Alarm Reporting	f9	6f	0e
Alarm Dismiss Report	f9	6f	0f
D2D Data Transmission Feature	f9	6f	10
D2D Controller Feature	f9	6f	11
D2D Controller CH1 Temperature Threshold Triggered	f9	6f	12
D2D Controller CH1 Temperature Threshold Released	f9	6f	13
D2D Controller CH1 Temperature Shift Change	f9	6f	14
D2D Controller CH1 Humidity Threshold Triggered	f9	6f	15
D2D Controller CH1 Humidity Threshold Released	f9	6f	16
D2D Controller CH1 Humidity Shift Change	f9	6f	17
D2D Controller CH1 Door Magnet Closed	f9	6f	18
D2D Controller CH1 Door Magnet Opened	f9	6f	19
D2D Controller CH2 Temperature Threshold Triggered	f9	6f	1a
D2D Controller CH2 Temperature Threshold Released	f9	6f	1b

Item	Channel	Type	Data
D2D Controller CH2 Temperature Shift Change	f9	6f	1c
D2D Controller CH2 Humidity Threshold Triggered	f9	6f	1d
D2D Controller CH2 Humidity Threshold Released	f9	6f	1e
D2D Controller CH2 Humidity Shift Change	f9	6f	1f
D2D Controller CH2 Door Magnet Closed	f9	6f	20
D2D Controller CH2 Door Magnet Opened	f9	6f	21
Data Storage	f9	6f	22
Data Retransmission Interval	f9	6f	23
Magnetic Switch Delayed Alarm Time	f9	6f	24
Historical Data Report interval	f9	6f	25
CH1 Temperature Calibration	f9	6f	26
CH1 Humidity Calibration	f9	6f	27
CH2 Temperature Calibration	f9	6f	28
CH2 Humidity Calibration	f9	6f	29
Daylight Saving Time	f9	6f	2a
Time Type	f9	6f	2b
Screen	f9	6f	2d
Data Retransmission	f9	6f	2e

Example 1:

Enquire the configuration of reporting interval.

f96f01		
Channel	Type	Value
f9	61	01= Report interval

Reply:

ff 8e 00 0a00		
Channel	Type	Value
ff	8e	0a00=>00 0a=10 mins

Example 2:

Enquire the configuration of daylight saving time.

f96f2a		
Channel	Type	Value
f9	6f	2a = Daylight Saving Time

Reply:

f9 72 bc 03 27 3c00 0a 27 3c00		
Channel	Type	Value
f9	72	bc=1011 1100=> enable daylight saving time, DST bias: 60 mins Start time: 03=>March, 27=>second Sunday, 3c 00 =>00 3c=60 minutes =1:00 End time: 0a=>10=October, 27=>second Sunday(7), 3c 00 =>00 3c=60 minutes =1:00

Commands for Historical Data Query

The device can query historical data for a specified time point or range through downlink commands. The specified time point can use [Unix Timestamp Converter](#) to calculate. The prerequisites are that the device time is correct and the **data storage function** is enabled. The device uploads a maximum of 300 data records per range query.

When querying data for a specific time point, the device uploads the record closest to the requested time within the current reporting interval. For example, with a 10-minute reporting interval, a query for 17:00 will return the exact record if it exists. Otherwise, the device searches for data within a tolerance of ±10 minutes (16:50 to 17:10) and uploads the record closest to 17:00.

Command format:

Item	Channel	Type	Description
Query data for a specified time point	fd	6b	4 Bytes, Unix timestamp
Query data for a specified time range	fd	6c	Start time (4 bytes) + end time (4 bytes), Unix timestamp
Stop data query report	fd	6d	ff
Report interval	ff	6a	3 bytes Byte 1: 01 Byte 2-3: interval time, unit:s, range: 30-1200 s, default: 60s

Reply format:



Item	Channel	Type	Description
Query Result	fc	6b/6c	00: data query success 01: invalid time point or time range 02: no data for this time point or time range
CH1 Data	20	ce	Data time stamp (4B) + chn_mask (1B) + Data (4B)
CH2 Data	21	ce	Data time stamp (4B) + chn_mask (1B) + Data (4B)

chn_mask:

Bit	7-4	3-0
	Temperature/Magnet	Humidity
	<ul style="list-style-type: none"> • 0000 = No • 0001 = Above (max. threshold) Alarm • 0010 = Above Dismiss 	

Bit	7-4	3-0
	<ul style="list-style-type: none"> • 0011 = Below (min. threshold) Alarm • 0100 = Below Dismiss • 0101 = Within Alarm • 0110 = Within Dismiss • 0111 = Beyond Alarm • 1000 = Beyond Dismiss • 1001 = Shift Alarm • 1010 = Periodic Report • 1011 = Magnet Alarm • 1100 = Overage Alarm • 1101 = Button Report 	

Data:

Probe	Byte 4-0
TH	Humidity (2B) + Temperature (2B) <div style="background-color: #e1f5fe; padding: 5px; border-radius: 5px;">  Note: When the value is out of range, it will report "16fc". </div>
PT100/DS18B20	0000 + Temperature (2B) <div style="background-color: #e1f5fe; padding: 5px; border-radius: 5px;">  Note: When the value is out of range, it will report "16fc". </div>
Magnet switch	<ul style="list-style-type: none"> • 19fc17fc: Open • 19fc18fc: Close

Example:

Enquire the historical data in a time range.

fd6c 64735b63 7c885b63		
Channel	Type	Value
fd	6c	Start time: 64 73 5b 63 => 63 5b 73 64 = 1666937700s End time: 7c 88 5b 63 => 63 5b 88 7c = 1666943100s

Reply:

fc6c00		
Channel	Type	Value
fc	6c	00: Enquiry success

20ce 0d755b63 041a021601			
Channel	Type	Time Stamp	Value
20	ce	0d 75 5b 63 => 63 5b 75 0d=1666938125s	04=0010: Above Dismiss Humidity: 1a 02 => 02 1a = 538/10 = 53.8%RH Temperature: 16 01 => 01 16= 278/10=27.8°C

Chapter 6. Services

Milesight provides customers with timely and comprehensive technical support services. End-users can contact your local dealer to obtain technical support. Distributors and resellers can contact directly with Milesight for technical support.

Technical Support Mailbox: iot.support@milesight.com

Online Support Portal: <https://support.milesight-iot.com>

Resource Download Center: <https://www.milesight.com/iot/resources/download-center/>

MILESIGHT CHINA

TEL: +86-592-5085280

FAX: +86-592-5023065

Add: Building C09, Software Park Phase III, Xiamen 361024, Fujian, China