



# Smart Radiator Thermostat

Featuring LoRaWAN®

**WT101**

User Guide



## Safety Precautions

Milesight will not shoulder responsibility for any loss or damage resulting from not following the instructions of this operating guide.

- ❖ The device must not be disassembled or remodeled in any way.
- ❖ Do not place the device where the temperature is below/above the operating range.
- ❖ Do not place the device close to objects with naked flames, or exposure to sunlight, cold source, liquid, and extreme temperature changes.
- ❖ Remove the battery from the device if it is not to be used for an extended period. Otherwise, the battery might leak and damage the device.
- ❖ The device must never be subjected to shocks or impacts.
- ❖ Be sure that there is no obstacle around to affect the air circulation.
- ❖ In order to protect the security of the device, please change device password when first configuration. Default password is 123456.
- ❖ The device is not intended to be used as a reference sensor, and Milesight will not should responsibility for any damage which may result from inaccurate readings.
- ❖ Do not clean the device with detergents or solvents such as benzene or alcohol. To clean the device, wipe with a soft moistened cloth. Use another soft, dry cloth to wipe dry.

## Declaration of Conformity

WT101 is in conformity with the essential requirements and other relevant provisions of the CE and RoHS.



## Copyright © 2011-2025 Milesight. All rights reserved.

All information in this guide is protected by copyright law. Whereby, no organization or individual shall copy or reproduce the whole or part of this user guide by any means without written authorization from Xiamen Milesight IoT Co., Ltd.

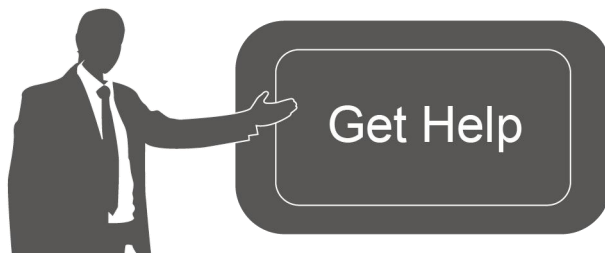

For assistance, please contact

Milesight technical support:

Email: [iot.support@milesight.com](mailto:iot.support@milesight.com)

Support Portal: [support.milesight-iot.com](http://support.milesight-iot.com)

Tel: 86-592-5085280

Fax: 86-592-5023065

Address: Building C09, Software Park  
Phase III, Xiamen 361024,  
China

## Revision History

Date	Doc Version	Description
Sept. 15, 2023	V 1.0	Initial version
June 18, 2024	V 1.1	Add BACnet control point list
August 16, 2024	V 1.2	<ol style="list-style-type: none"><li>1. Support to enable or disable ambient temperature display;</li><li>2. Support to configure time zone and DST time;</li><li>3. Support to configure effective stroke;</li><li>4. Support to report TSL version number;</li><li>5. Support to receive external temperature sensor data via downlink command;</li><li>6. Support command to configure heat schedule, change report, offline mode, etc.</li></ol>

# Contents

1. Product Introduction .....	5
1.1 Overview .....	5
1.2 Key Features .....	5
2. Hardware Introduction .....	5
2.1 Packing List .....	5
2.2 Hardware Overview .....	6
2.3 Button and LED Patterns .....	7
2.4 Dimensions (mm) .....	7
3. Power Supply .....	7
4. Installation Instruction .....	8
4.1 Adapter Selection .....	8
4.2 Thermostat Installation .....	9
5. Operation Guide .....	10
5.1 NFC Configuration .....	10
5.2 LoRaWAN® Settings .....	11
5.3 General Settings .....	13
5.4 Advanced Settings .....	17
5.4.1 Calibration Settings .....	17
5.4.2 Heat Schedule .....	18
5.5 Maintenance .....	19
5.5.1 Backup .....	19
5.5.2 Upgrade .....	21
5.5.3 Reset to Factory Default .....	21
6. Communication Protocol .....	22
6.1 Basic Information .....	22
6.2 Sensor Data .....	23
6.3 Downlink Commands .....	25
6.3.1 General Settings .....	25
6.3.2 Calibration Settings .....	28
6.3.3 Heat Schedule Settings .....	28
6.3.4 External Sensor Mode .....	29
7. BACnet Control Point List .....	30

## 1. Product Introduction

### 1.1 Overview

WT101, a LoRaWAN® radiator thermostat to help with managing the heating-control system. With 1 pre-set date period and up to 16 customized heating plans, it enables the smart management of heating system and save unnecessary cost in a way. WT101 is a smart and highly environment-sensitive products, abnormal temperature difference and extreme-low temperature can quickly trigger it and it will take fast steps in correcting them by adjusting the valve opening.

Compliant with Milesight LoRaWAN® gateway and Milesight IoT Cloud solution, users can control the room temperature as well as triggering other sensors or appliances easily via webpage or mobile App remotely.

### 1.2 Key Features

- Adjust the room temperature automatically and manually with a time-controlled regulation
- Up to 16 heating schedules within 1 pre-set Date Period
- Built-in temperature sensor, enabling environmental detection and accurate control
- Intuitive and direction adjustment LED display to suit different installation environments
- Support open-window detection and freeze protection
- Equip with child-lock to enable tamper-proof in public area
- Tamper button design and theft-detering collar for structural anti-theft protection
- Suit most common radiator valves with optional valve adapters for universal use
- Easy to install with simple lock design without further setting
- Equipped with NFC for one-touch configuration
- Function well with standard LoRaWAN® gateways and network servers

## 2. Hardware Introduction

### 2.1 Packing List



1 × WT101 Device  
(With Valve Base Plate)



2 × Li-FeS<sub>2</sub> AA  
Batteries



1 × Hex Socket Cap  
Fixing Screw



1 × Screw Cap



1 × Theft-deterrent Collar Kit



1 × Quick Start Guide



1 × Warranty Card



1 × Valve Adapter Kit (Optional)

A valve adapter kit includes below accessories:

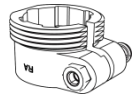

Danfoss RA



Danfoss RAVL

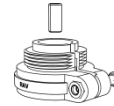

Danfoss RAV



Giacomini

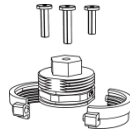

M28 (Comap, Herz, TA)



If any of the above items are missing or damaged, please contact your sales representative.

## 2.2 Hardware Overview

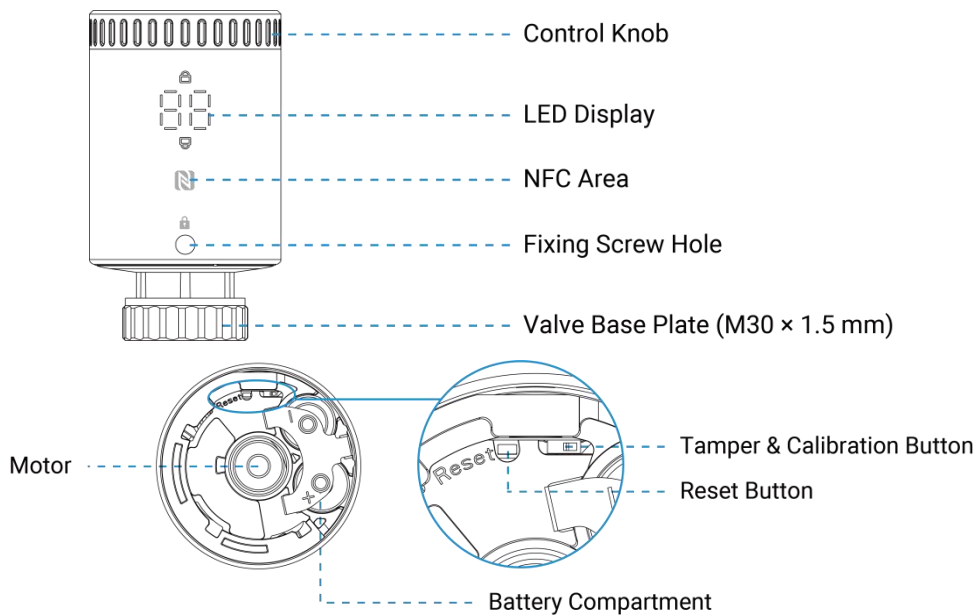

The motor is used to push the radiator valves to open or close as required.

## 2.3 Button and LED Patterns

Function	Action	LED Display
Check On/Off Status	Quick press the reset button once or rotate the control knob.	Light On: Device is on. Light Off: Device is off.
Reboot	Press and hold the reset button for more than 3 seconds.	Blink slowly
Reset to Factory Default	Press and hold the reset button for more than 10 seconds.	Blink quickly
Motor Stroke Calibration	The device is installed and the tamper & calibration button is pressed.	Flashes in circle → Blinks twice
Tamper	The device is removed and the tamper & calibration button is released.	Light on for 1s

## 2.4 Dimensions (mm)

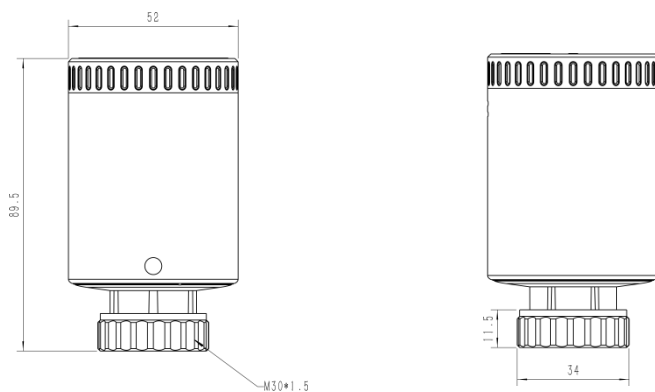

## 3. Power Supply

1. Separate the base plate from the device by rotating it anticlockwise.

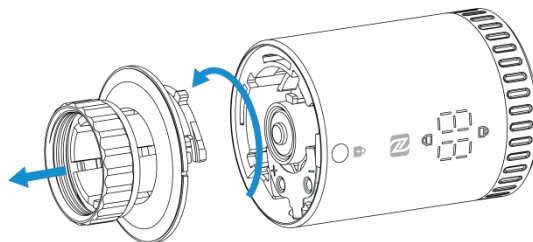

2. Open the metal battery cover by pushing it.

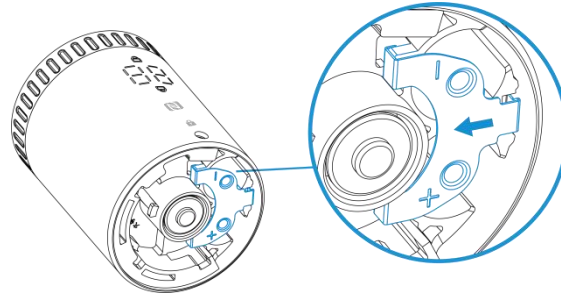

3. Install the two batteries with correct direction, which is shown on the battery cover.

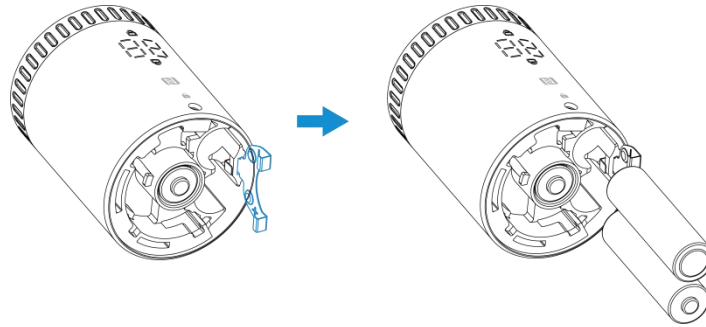

4. Restore the battery cover in place. After installing the batteries, the device will turn on automatically and the LED display will light on for 3s.

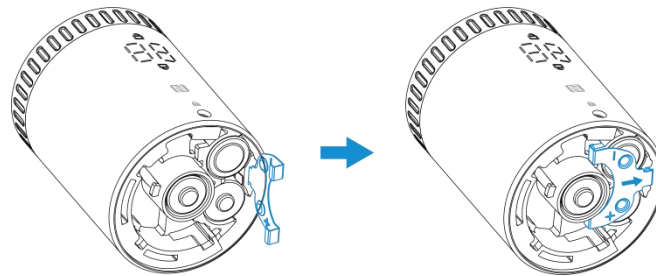

**Note:**

- 1) The device can be powered by 1.5V AA Li-FeS<sub>2</sub> or alkaline batteries, not Li-SoCl<sub>2</sub> batteries.
- 2) It is suggested to use batteries with maximum output current more than 750mA, which has a longer battery life. The battery life of normal alkaline batteries is very short.
- 3) Make sure both batteries are newest when install, otherwise battery life will be reduced or the battery level will be error calculated.
- 4) After installing the batteries, the device will show and report battery level as 100% at the first time even for old batteries. The device will calculate the battery level after one hour.

## 4. Installation Instruction

### 4.1 Adapter Selection

The valve base plate can be used for all valves with a thread size of M30 × 1.5 mm from the most common manufacturers without any accessories. For other valve types, select the

corresponding adapter and mount it on the valve.

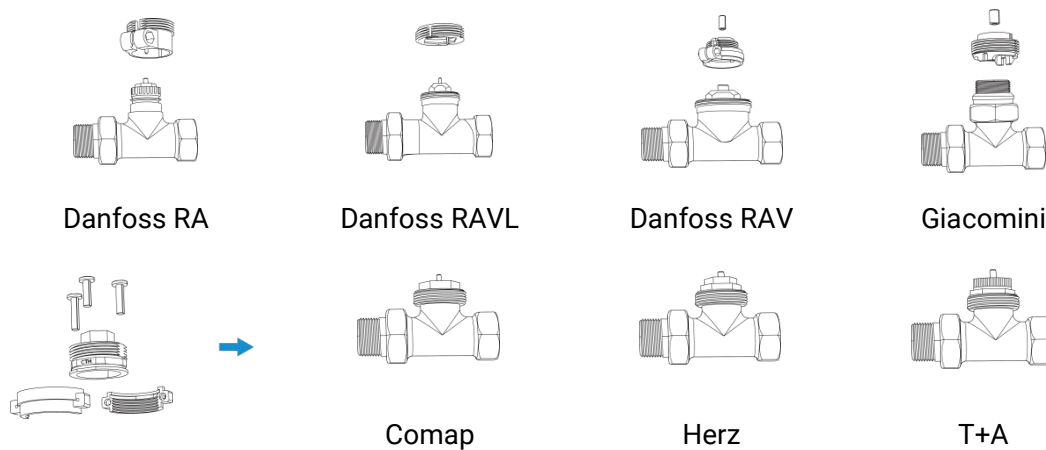

## 4.2 Thermostat Installation

1. Place the base plate on the valve or valve adapter and screw it tightly. The arrow on the base plate should be faced to the direction of display.

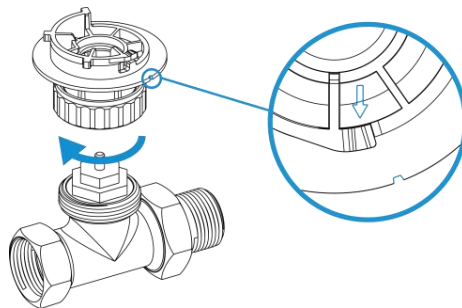

2. Rotate the device clockwise to secure it on the base plate and fix the hex socket cap fixing screw to the screw hole on the front of device. When rotating and device to base plate, the calibration & tamper button will be pressed and the motor on the device will start calibrating. When the LED displays the temperature with two blinks, the calibration is completed.

3. Cover the fixing screw with the screw cap.

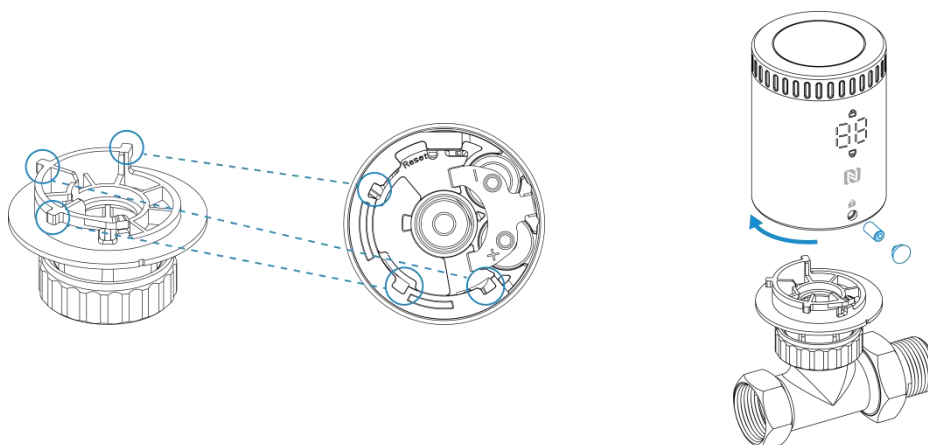

4. Add anti-theft accessories to avoid the device to be moved.

**Solution 1:** Fix the theft-detering collar to the base plate with screw and the nut.

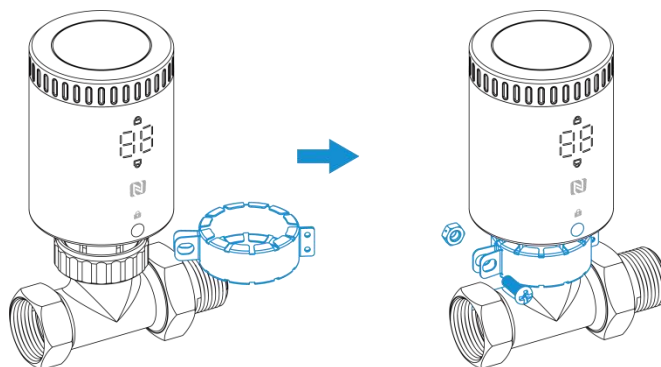

**Solution 2(optional):** Cover the whole device with a plastic protective anti-vandal cover.

1) Press down firmly on the right side of the cover, then pull it apart from both sides.

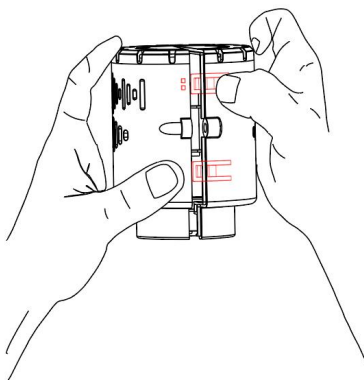

2) Place the cover onto the device, close it, then secure it with a screw.

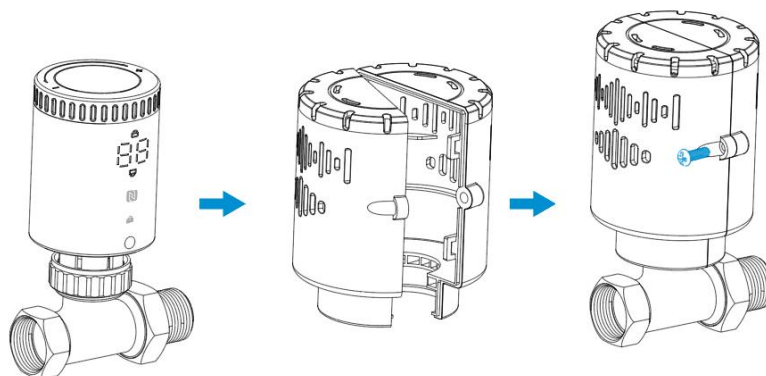

## 5. Operation Guide

### 5.1 NFC Configuration

WT101 can be monitored and configured via NFC. Please refer to the following configuration steps.

1. Download and install the Milesight ToolBox App from Google Play or Apple App Store.

2. Enable NFC on the smartphone and launch Milesight ToolBox.
3. Attach the NFC area of a smartphone to the device, and click **NFC Read** to read device information. The basic information and settings of the device will be shown on ToolBox App if it's recognized successfully. You can read and configure the device by tapping the Read/Write device on the App. In order to protect the security of the device, please change the password when first configuring. The default password is **123456**.

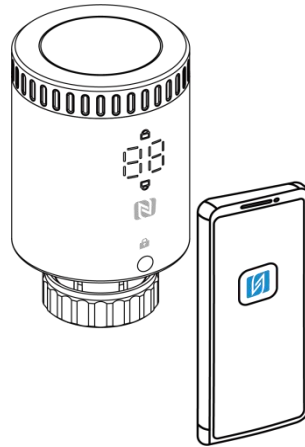

**Note:**

- 1) Ensure the location of NFC area of the smartphone and it's recommended to take off phone case.
- 2) If the smartphone fails to read/write configurations via NFC, remove the phone and try again.

## 5.2 LoRaWAN® Settings

Configure AppEUI, Join Type, Application Key, and other basic LoRaWAN® information. You can also keep all settings by default.

Device EUI

24E124791D196040

\* APP EUI

24e124c0002a0001

\* Application Port  85

Join Type

ABP

\* Network Session Key

\*\*\*\*\*

\* Application Session Key

\*\*\*\*\*

Parameters	Description
Device EUI	Unique ID of the device which can also be found on the label.
App EUI	The default App EUI is 24E124C0002A0001.
Application Port	The port is used for sending and receiving data, the default port is 85.
Join Type	OTAA and ABP modes are available.
Application Key	Appkey for OTAA mode, default value: "Device EUI" + "Device EUI" (since Q4 of 2025). Example: 24e124123456789024e1241234567890 <b>Note:</b> The default value of earlier devices is 5572404C696E6B4C6F52613230313823.
Network Session Key	Nwkskey for ABP mode, the default is 5572404C696E6B4C6F52613230313823.
Application Session Key	Appskey for ABP mode, the default is 5572404C696E6B4C6F52613230313823.
Device Address	DevAddr for ABP mode, the default is the 5th to 12th digits of the SN.
LoRaWAN® Version	V1.0.2 and V1.0.3 are available.
Work Mode	It's fixed as Class A.
RX2 Data Rate	RX2 data rate to receive downlinks.
RX2 Frequency	RX2 frequency to receive downlinks. Unit: Hz
Supported Frequency	Select the frequency plan and enable the frequencies to send uplinks.

Confirmed Mode	If the device does not receive an ACK packet from the network server, it will resend data once.
Rejoin Mode	Reporting interval $\leq$ 35 mins: the device will send a specific number of LinkCheckReq MAC packets to the network server every reporting interval or every double reporting interval to validate connectivity; If there is no response, the device will re-join the network. Reporting interval $>$ 35 mins: the device will send a specific number of LinkCheckReq MAC packets to the network server every reporting interval to validate connectivity; If there is no response, the device will re-join the network.
Set the number of packets sent	When the rejoin mode is enabled, set the number of LinkCheckReq packets to send. <b>Note:</b> the actual sending number is <b>Set the number of packet sent + 1</b> .
ADR Mode	Allow network server to adjust data rate of the device.
Spread Factor	If ADR is disabled, the device will send data via this spread factor.
Tx Power	Transmit power of the device.

**Note:**

- 1) Please contact sales for device EUI list if there are many units.
- 2) Please contact sales if you need random App keys before purchase.
- 3) Select OTAA mode if you use Milesight IoT cloud or Milesight Development Platform to manage devices.
- 4) Only OTAA mode supports rejoin mode.

### 5.3 General Settings

Reporting Interval(min)

Temperature Unit

Mounting Orientation ⓘ

Ambient Temperature Display

Temperature Control

Temperature Control Mode

Automatic Temperature Co... ▼

Freeze Protection

3 °C

Child Locks

Time Zone

UTC (WET: Western Europe... ▼

Daylight Saving Time



Start Time Mar. | 2nd | Sun. | 00:00 🕒

End Time Nov. | 1st | Mon. | 00:00 🕒

DST Bias(min) ⓘ

60

Change Password

Parameters	Description
Reporting Interval	The interval of reporting battery level, temperature, motor status to network server. Default: 10 min, Range: 1 - 1440 min
Temperature Unit	Set the unit of temperature displayed on the LED display and configuration page.
Mounting Orientation	Set the LED display direction to suit thermostat mounting orientation. <div style="display: flex; justify-content: space-around; align-items: center;"> <div style="text-align: center;">  <p><b>Horizontal</b></p> </div> <div style="text-align: center;">  <p><b>Vertical</b></p> </div> </div>

Ambient Temperature Display	Enable to display ambient temperature for a while after rotating the control knob.
Temperature Control	Disable or enable the device to control the valve to adjust temperature. After enabled, the device will start calibrating the motor once.
Temperature Control Mode	Select from Automatic Temperature Control or Valve Opening Control.
Freeze Protection	When the device detects the temperature is lower than the threshold temperature, control the valve opening status every 10 minutes to adjust the temperature to threshold temperature ( $\pm$ target temperature tolerance).
Child Lock	Lock the control knob to control the valve. After enabled, the device can only control the valve via ToolBox App or downlink commands.
Time Zone	Set the device time zone. When you click <b>Sync</b> button of ToolBox App to sync time, the device will also sync the time zone from smartphone automatically.
Daylight Saving Time	Enable or disable Daylight Saving Time (DST). <b>Start Time:</b> the start time of DST time range. <b>End Time:</b> the end time of DST time range. <b>DST Bias:</b> the DST time will be faster according to this bias setting.
Change Password	Change the password for ToolBox App to write this device.

**Automatic Temperature Control:** set target temperature to control the valve opening status. When using this mode, the target temperature can be set via ToolBox App, control knob or downlink command.

Temperature Control

Temperature Control Mode  
Automatic Temperature Control ▼

Target Temperature  
19 °C

Target Temperature Tolerance  
1 °C

Target Temperature Regulation Range  
10 °C - 25 °C

Open Window Detection ⓘ

Cooling Rate  
≥ 3 °C / min

Stop temperature control for - 30 + min

Parameters	Description
Target Temperature	Set target environment temperature. The device will adjust the valve every 10 minutes if the gap between target temperature and current temperature is more than tolerance value.
Target Temperature Tolerance	Set the tolerance value between target temperature and current temperature.
Target Temperature Regulation Range	Set the range for control knob to adjust the target temperature. Max range: 16 - 35 °C, min range: 5 - 15 °C, default range: 10 - 28 °C.
Open Window Detection	When the device detects the temperature drops over cooling rate, it will stop temperature control and report open window status; when the device detects the temperature rising for 10 minutes or reaching target temperature, it will start temperature control and report normal status.
Cooling Rate	Set the detecting condition of window open.
Stop temperature control for..	The device will start temperature control even it still detects the window open after this interval.

**Valve Opening Control:** control valve opening status to adjust the temperature. 0% means valve is all closed and 100% means valve is all open. When using this mode, the valve opening percentage can be set via ToolBox App, control knob or downlink command.

**Note:**

- 1) When rotating the control knob, the LED display will show corresponding valve opening percentage and current temperature. Every rotating step is 5%.
- 2) When setting the valve opening percentage as 100%, the LED display will only show 99.

Temperature Control

Temperature Control Mode

Valve Opening Control ▾

Valve Opening

50 %

## 5.4 Advanced Settings

### 5.4.1 Calibration Settings

**Motor Stroke Calibration:** click to calibrate the motor stroke when the device is installed to the valve. After calibration, the device will report a calibration result packet.

**Effective Stroke:** enable to limit the maximum valve opening to limit the maximum heat dissipation (hot water amount) of the radiator and achieve the hydraulic balancing.

**Temperature Calibration:** set the calibration value, the device will add calibration value to the current temperature value and report the final value.

Motor Stroke [Stroke Calibration](#)

Effective Stroke(%) ⓘ

100

The effective stroke is - steps

---

Temperature

Current Value(°C)	Final Value(°C)
<b>27</b>	<b>26</b>

Calibration Value(°C)

-1

## 5.4.2 Heat Schedule

WT101 supports to set at most 16 heat schedules within 1 pre-set date period.

1. Sync the device time via ToolBox App. Besides, the device can also ask for the time from network server when setting LoRaWAN® version as 1.0.3.

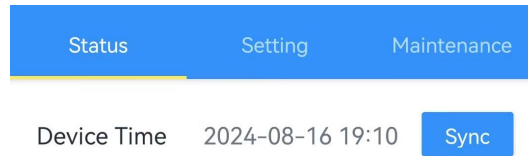

2. Set a heating date period, and the reporting interval except the heating date period. Temperature control will stop during non-heating period.

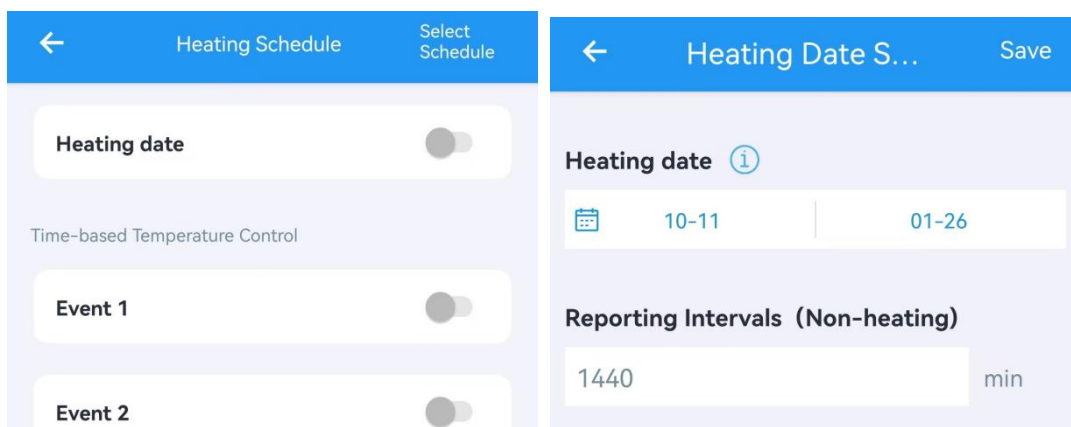

3. Set time-based control events and these events only execute within the heating date period. If the repeat day is not selected, this event will only execute once.

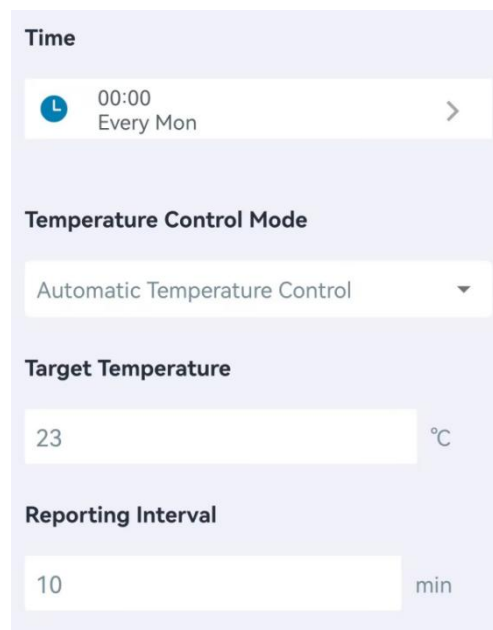

**Time**

🕒 01:00

Repeat

Every Mon.	<input checked="" type="radio"/>
Every Tues.	<input checked="" type="radio"/>
Every Wed.	<input type="radio"/>
Every Thur.	<input type="radio"/>
Every Fri.	<input type="radio"/>
Every Sat.	<input type="radio"/>
Every Sun.	<input checked="" type="radio"/>

01:00  
Every Mon. Tues. Sun.

4. Click **Save Schedule** to export above settings as a schedule file.

Event 15

Event 16

Save Schedule

Clear All

Click **Select Schedule** to import the schedule file to another device.

← Heating Schedule Select Schedule

Event 15

## 5.5 Maintenance

### 5.5.1 Backup

WT101 supports backup templates for easy and quick configuring devices in bulk. The backup

feature is only for devices with the same model and LoRaWAN® frequency band.

1. Go to **Template** page on the App and save the current settings as a template. The saved templates are also editable.



2. Select one saved template and click **Write**, then attach the smartphone to another device via NFC to reuse the template.

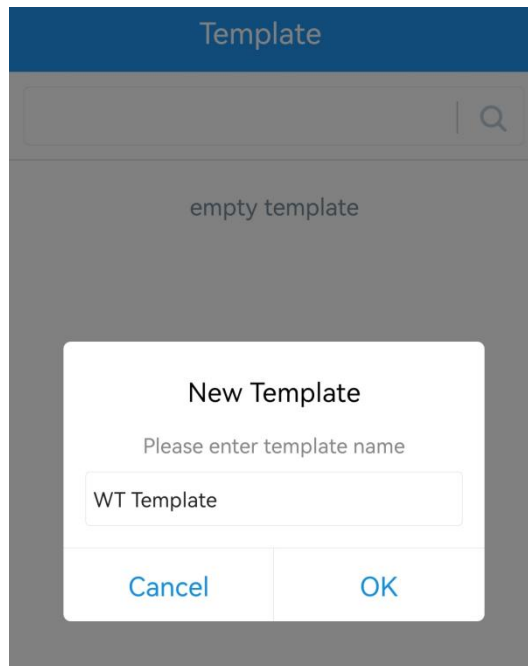

**Note:** Slide the template item to the left to edit or delete the template. Click the template to edit the configurations.

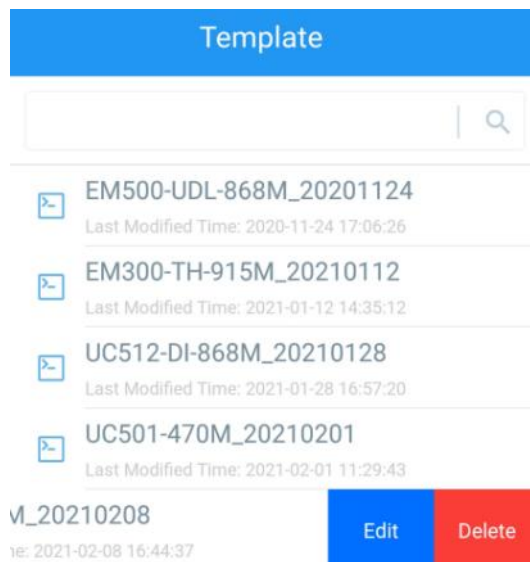

### 5.5.2 Upgrade

1. Download firmware from the Milesight website to your smartphone.
2. Go to **Device > Maintenance** of ToolBox App, tap **Browse** to import firmware and upgrade the device.

**Note:** Operation on ToolBox is not supported during the upgrade.

Status	Setting	Maintenance
SN	6714D24178280000	
Model	WT101-868M	
Firmware Version	V1.1-a3	
Hardware Version	V1.0	
Manual Upgrade		

[Browse](#)

### 5.5.3 Reset to Factory Default

WT101 supports two methods to reset the device which are as following:

**Via Hardware:** Press and hold the reset button for more than 10s until the LED display blinks quickly.

**Via ToolBox App:** Go to **Device > Maintenance** to tap **Reset**, then attach the smartphone to the device via NFC to complete the reset.

Status	Setting	Maintenance
SN	6714D24178280000	
Model	WT101-868M	
Firmware Version	V1.1-a3	
Hardware Version	V1.0	
Manual Upgrade		
Browse		
Restore Factory Default		
Reset		
Reboot		

## 6. Communication Protocol

All the data is based on the following format (HEX), the Data field should follow the little-endian:

Channel1	Type1	Data1	Channel2	Type2	Data2	Channel 3	...
1 Byte	1 Byte	N Bytes	1 Byte	1 Byte	M Bytes	1 Byte	...

For decoder and encoder examples please find the files on

<https://github.com/Milesight-IoT/SensorDecoders>.

### 6.1 Basic Information

WT101 reports basic information whenever joining the network.

Channel	Type	Description
ff	0b (Power On)	Device is on
	01 (Protocol Version)	01 => V1
	16 (Device SN)	16 digits
	09 (Hardware Version)	01 40 => V1.4
	0a (Software Version)	01 14 => V1.14
	0f (Device Type)	00: Class A, 01: Class B, 02: Class C
	ff (TSL Version)	01 00 => V1.0

**Example:**

ff0bff ff0101 ffff0100 ff166791d19604050005 ff090100 ff0a0101 ff0f00					
Channel	Type	Value	Channel	Type	Value
ff	0b (Power On)	ff (Reserved)	ff	01 (Protocol Version)	01 (V1)
Channel	Type	Value	Channel	Type	Value
ff	ff (TSL Version)	0100 (V1.0)	ff	16 (Device SN)	6791d19 6040500 05
Channel	Type	Value	Channel	Type	Value
ff	09 (Hardware Version)	0100 (V1.0)	ff	0a (Software Version)	0101 (V1.1)
Channel	Type	Value			
ff	0f (Device Type)	00 (Class A)			

**6.2 Sensor Data**

Item	Channel	Type	Description
Battery Level	01	75	UINT8, Unit: % <b>Note:</b> the device will report a low battery packet when it drops to 10%.
Current Temperature	03	67	INT16/10, Unit: °C
Target Temperature	04	67	INT16/10, Unit: °C
Valve Opening Percentage	05	92	UINT8, Unit: %
Tamper Status	06	00	00: Installed, 01: Uninstalled
Open Window Detection	07	00	00: Normal, 01: Open
Motor Calibration Result	08	e5	00: Success 01: Fail, out of range 02: Fail, uninstalled 03: Calibration cleared 04: Temperature control disabled
Motor Stroke	09	90	UINT16
Freeze Protection	0a	00	00: Back to Normal, 01: Triggered
Motor Position	0b	90	UINT16, current motor position

			<b>Note:</b> when motor position =motor stroke, the valve is all closed; when motor position is 0, the valve is all open.
--	--	--	---

**Examples:**

1. Automatic Temperature Control periodic packet: report as reporting interval (10 minutes by default).

017564 0467e600 03670701 0b903a02 09903a02					
Channel	Type	Value	Channel	Type	Value
01	75	64=>100%	03	67	Current Temp.: 07 01=>01 07=263/10=26.3°C
Channel	Type	Value	Channel	Type	Value
04	67	Target Temp.: e6 00=>00 e6=230/10=23°C	09	90	Motor Stroke: 3a 02=>02 3a=570
Channel	Type	Value			
0b	90	Motor Position: 3a 02=>02 3a=570			

2. Valve Opening Control periodic packet: report as reporting interval (10 minutes by default).

017564 03670f01 05925f 0b901c00 09904002					
Channel	Type	Value	Channel	Type	Value
01	75	64=>100%	03	67	Current Temp: 0f 01=>01 0f =271/10=27.1°C
Channel	Type	Value	Channel	Type	Value
05	92	5f=>95%	09	90	Motor Stroke: 40 02=>02 40=576
Channel	Type	Value			
0b	90	Motor Position: 1c 00=>00 1c=28			

3. Motor calibration packet: report when the motor start calibrating.

08e500 09903a02					
Channel	Type	Value	Channel	Type	Value
08	e5	00=success	09	90	Motor Stroke: 3a 02=>02 3a=570

4. Open Window Detection: reports when detecting the window open or returns back to normal status.

070001 03679600					
Channel	Type	Value	Channel	Type	Value
07	00	01=open	03	67	Temperature: 96 00 =>00 96 = 150/10 = 15 °C

5. Freeze Protection: report when freeze protection is triggered or released.

0a0001 03671500 05925f					
Channel	Type	Value	Channel	Type	Value
0a	00	01=freeze protection is triggered	03	67	Temperature: 15 00 =>00 15 = 21/10 = 2.1 °C
Channel	Type	Value			
05	92	5f=>95%			

6. Tamper packet: report when the device is removed from base plate.

060001 08e503					
Channel	Type	Value	Channel	Type	Value
06	00	01=uninstalled	08	e5	03=Calibration cleared

## 6.3 Downlink Commands

WT101 supports downlink commands to configure the device. The application port is 85 by default.

### 6.3.1 General Settings

Item	Channel	Type	Byte	Description
Reboot	ff	10	1	ff
Reporting Interval	ff	8e	3	Byte 1: 00 Byte 2-3: interval time, unit: min
Ambient Temperature Display	f9	36	1	00-disable, 01-enable
Temperature Control	ff	b3	1	00-disable, 01-enable
Temperature Control Mode	ff	ae	1	00: Automatic Temperature Control 01: Valve Opening Control
Target Temperature	ff	b1	3	Byte 1: target temperature, INT8, unit: °C Byte 2-3: target temperature tolerance, UINT16/10, unit: °C
Target Temperature Regulation Range	f9	35	2	Byte 1: Min. Value[5-15], unit: °C Byte 2: Max. Value[16-35], unit: °C
Open Window Detection	ff	af	4	Byte 1: 00-disable, 01-enable

				Byte 2: cooling rate, INT8/10, unit: °C/min Byte 3-4: stop temperature control time, unit: min				
Release Open Window Status	ff	57	1	ff				
Open Window Detection Valve Strategy	f9	37	1	00: keep current status (default) 01: close the valve				
Valve Opening Percentage	ff	b4	1	UINT8, unit: %				
Freeze Protection	ff	b0	3	Byte 1: 00-disable, 01-enable Byte 2-3: threshold temperature, INT16/10, unit: °C				
Child Lock	ff	25	1	00-disable, 01-enable				
UTC Time Zone	ff	bd	1	INT16/60				
Daylight Saving Time	ff	ba	10	Byte 1: 00-disable, 01-enable Byte 2: DST bias, unit: min Byte 3-6: Start time, Month (1B)+Week (1B) + Hours of a Day (2B) Week: <table border="1" style="margin-left: 20px;"> <thead> <tr> <th style="background-color: #0056b3; color: white;">Bit7-4</th> <th style="background-color: #0056b3; color: white;">Bit3-0</th> </tr> </thead> <tbody> <tr> <td>1: 1<sup>st</sup>, 2: 2<sup>nd</sup>, ...</td> <td>1: Monday, 2: Tuesday, ... 7: Sunday</td> </tr> </tbody> </table> Byte 7-10: End time	Bit7-4	Bit3-0	1: 1 <sup>st</sup> , 2: 2 <sup>nd</sup> , ...	1: Monday, 2: Tuesday, ... 7: Sunday
Bit7-4	Bit3-0							
1: 1 <sup>st</sup> , 2: 2 <sup>nd</sup> , ...	1: Monday, 2: Tuesday, ... 7: Sunday							
Change Report	f9	3a	1	01: report a packet once target temperature or valve opening percentage changes 00: disable change report				
Offline Control Mode	ff	f8	1	When the device is disconnected from server, 00: keep current valve status 01: switch to automatic temperature control mode 02: disable temperature control				

**Examples:**

- 1) Reboot the device.

<b>ff10ff</b>		
Channel	Type	Value
ff	10 (Reboot)	ff

- 2) Set reporting interval as 2 minutes.

<b>ff8e 00 0200</b>
---------------------

Channel	Type	Value
ff	8e (Reporting Interval)	02 00=>00 02=>2 mins

3) Set time zone.

ffbd10ff		
Channel	Type	Value
ff	bd	10 ff => ff 10 = -240/60=-4 the time zone is UTC-4

4) Set DST time: start time is October 1<sup>st</sup> Sunday 2:00, end time is April 1<sup>st</sup> Sunday 2:00, and bias is 1h (60 minutes).

ffba 01 3c 0a177800 04177800		
Channel	Type	Value
ff	ba	01=enable DST bias: 3c=>60 mins Start time: 0a=>10=October, 17=>1 <sup>st</sup> (1) Sunday(7), 78 00 =>00 78=120 hours=2:00 End time: 04=>April, 17=>1 <sup>st</sup> (1) Sunday(7), 78 00 =>00 78=120 hours=2:00

5) Set target temperature.

ffb1190100		
Channel	Type	Value
ff	b1 (Target Temperature)	Target temperature: 19 =>25 °C Temperature Tolerance: 0100=>00 01/10=0.1°C

6) Set target temperature regulation range between 5°C to 30°C.

f935051e		
Channel	Type	Value
f9	35 (Target Temperature Regulation Range)	Min. Value: 05=5°C Max. Value: 1e=30°C

7) Set open window detection.

ffaf011e 3c00		
Channel	Type	Value
ff	af (Open Window Detection)	01=enable Cooling rate: 1e=30/10=3 °C/min Stop control time: 3c00=>00 3c=60 minutes

8) Set valve opening percentage.

ffb432		
--------	--	--

Channel	Type	Value
ff	b4 (Valve Opening Percentage)	32=>50%

9) Set freeze protection.

ffb0011e00		
Channel	Type	Value
ff	b0 (Freeze Protection)	01=enable Threshold temperature: 1e00=>00 1e=30/10=3 °C

### 6.3.2 Calibration Settings

Item	Channel	Type	Byte	Description
Stroke Calibration	ff	ad	1	ff
Effective Stroke	f9	38	2	Byte 1: 00-disable, 01-enable Byte 2: percentage, UINT8, Unit: %
Temperature Calibration	ff	ab	3	Byte 1: 00-disable, 01-enable Byte 2-3: INT16/10, Unit: °C

#### Examples:

1. Enable temperature and set calibration value.

ffab01fdff		
Channel	Type	Value
ff	ab (Temperature Calibration)	01=Enable fdff=>fffd=-3/10=-0.3°C

### 6.3.3 Heat Schedule Settings

Item	Channel	Type	Byte	Description
Heating Date	f9	33	7	Byte 1: 00-disable, 01-enable Byte 2-3: non-heating reporting interval, unit: min Byte 4: start month [1-12] Byte 5: start day [1-31] Byte 6: end month [1-12] Byte 7: end day [1-31]
Heating Event	f9	34	9	Byte 1: event ID [0-15] Byte 2: 00-disable, 01-enable Byte 3: 00=Automatic Temperature Control, 01=Valve Opening Control

				<p>Byte 4: target temperature (unit: °C) or valve opening percentage (unit: %)</p> <p>Byte 5-6: reporting interval, unit: min</p> <p>Byte 7-8: start time, unit: min</p> <p>Byte 9: repeat day, 0=disable, 1=enable</p> <table border="1"> <tr> <th>Bit7</th> <th>.....</th> <th>Bit1</th> <th>Bit0</th> </tr> <tr> <td>Sun.</td> <td>,...</td> <td>Mon.</td> <td>0</td> </tr> </table>	Bit7	.....	Bit1	Bit0	Sun.	,...	Mon.	0
Bit7	.....	Bit1	Bit0									
Sun.	,...	Mon.	0									
Query Heat Schedule	ff	28	01	<p>01: enquiry heating date</p> <p>02: enquiry heating event</p> <p><b>Note:</b> even the event content is blank, the device will also reply totally 16 records.</p>								

**Examples:**

1) Set heating date between October 27<sup>th</sup> to March 31<sup>st</sup>.

f933 01 a005 0a1b 031f		
Channel	Type	Value
f9	33 (Heating Date)	01=Enable a005=>05a0=1440 mins 0a 1b => October 27 <sup>th</sup> 03 1f=> March 31 <sup>st</sup>

2) Set heating event 1.

f934 00 01 00 14 0a00 3804 c0		
Channel	Type	Value
f9	34 (Heating Event)	00=event 1 01=enable 00=Automatic Temperature Control Target Temperature: 14=>20°C 0a 00=> 00 0a =10 minutes 38 04=> 04 38= 1080 minutes =18:00 c0 => 11000000 =repeat every Sunday and Saturday)

**6.3.4 External Sensor Mode**

WT101 supports to disable internal temperature sensor and use external temperature sensor data via downlink commands.

Item	Channel	Type	Byte	Description
External Temperature	ff	c4	2	Byte 1: 00-disable, 01-enable

Sensor Mode				Byte 2: timeout, unit: min <b>Note:</b> when the device does not receive the temperature for timeout, it will stop working to control the temperature.
External Temperature	03	-	3	Byte 1-2: INT16/10, unit: °C Byte 3: 00
Offline Control Mode	ff	f8	1	When the device is disconnected from server, 00: keep current valve status 01: switch to internal temperature sensor 02: disable temperature control

**Examples:**

- 1) Enable external temperature sensor and set the timeout as 60 minutes.

ffc4013c		
Channel	Type	Value
ff	c4 (External Temperature Sensor)	01=Enable 3c=> 60 minutes

- 2) Send external temperature sensor data.

03640000	
Channel	Value
03	64 00=>00 64=100/10=10 °C

## 7. BACnet Control Point List

When WT101 is integrated to BACnet system via Milesight gateway or Milesight default decoder and encoder, please refer to below list to read and write BACnet objects.

**Note:**

- 1) **The reference parameters points the objects to be written together, otherwise the parameters will be failed to change. When users write multiple reference parameters via Milesight gateway, ensure these values are sent within 60s.**

- 2) ●=Read only, ●=Read and Write, ●=Write Only.

Parameter	LoRa Object	Object Type	Description	Reference Parameter
Protocol Version	ipso_version	characterString Value		
Hardware Version	hardware_version	characterString		

		ng Value		
Firmware Version	firmware_version	characterString Value		
Power On Status	device_status	Binary Input	1: Power on	
Class Type	lorawan_class	Multistate Value	1: Class A 2: Class B 3: Class C 4: Class C to B	
Device SN	sn	characterString Value		
Battery Level	battery	Analog Input	Unit: %(98)	
Temperature	temperature	Analog Input	Unit: °C(62)	
Target Temperature	temperature_target	Analog Value	Unit: °C(62)	temperature_error
Valve Opening Percentage	valve_opening	Analog Value	Unit: %(98)	
Tamper Status	tamper_status	Binary Input	0: Installed 1: Uninstalled	
Open Window Detection	window_detection	Binary Input	0: Normal 1: Open	
Motor Calibration Result	motor_calibration_result	MultiState Value	1: Success 2: Fail, out of range 3: Fail, uninstalled 4: Calibration cleared 5: Temperature control disabled	
Motor Stroke	motor_storke	Analog Input	Unit: no-units(95)	
Freeze Protection	freeze_protection	Binary Input	0: Off, 1: On	
Motor Position	motor_position	Analog Input	Unit: no-units(95)	
Reboot	reboot	Binary Output	0: No, 1: Yes	
Time Sync	sync_time	Binary Output	0: No, 1: Yes	
UTC Time Zone	timezone	Analog Value	Unit: no-units(95)	

Query Current Status	report_status	Binary Output	0: No, 1: Yes	
Report Interval	report_interval	Analog Value	Unit: min(72)	
Temperature Calibration Enable	temperature_calibration.enable	Binary Value	0: Disable, 1: Enable	Both objects should be written together
Temperature Calibration Value	temperature_calibration.temperature	Analog Value	Unit: °C(62)	
Temperature Control	temperature_control.enable	Binary Value	0: Disable, 1: Enable	
Temperature Control Mode	temperature_control.mode	MultiState Value	1: Automatic Temperature Control 2: Valve Opening Control	
Target Temperature Tolerance	temperature_error	Analog Value	Unit: °C(62)	temperature_target
Open Window Detection Enable	open_window_detection.enable	Binary Value	0: Disable, 1: Enable	These objects should be written together
Open Window Detection Cool Rate	open_window_detection.temperature_threshold	Analog Value	Unit: °C(62)	
Open Window Detection Stop Temperature Control Time	open_window_detection.time	Analog Value	Unit: min(72)	
Release Open Window Status	restore_open_window_detection	Binary Output	0: No, 1: Yes	
Valve Calibration	valve_calibration	Binary Output	0: No, 1: Yes	
Freeze Protection Enable	freeze_protection_config.enable	Binary Value	0: Disable, 1: Enable	Both objects should be written together
Freeze Protection Temperature	freeze_protection_config.temperature	Analog Value	Unit: °C(62)	
Child Lock	child_lock_config	Binary Value	0: Disable, 1: Enable	

	.enable			
--	---------	--	--	--

**-END-**