



I Series Sensors for Humidity and Temperature For digital data transfer RS485 / MODBUS RTU or RS232

-humidity/-temperature sensors in the I series are compact sensors in a rod-type design with cable, connecting head or plug-in connection to measure relative humidity and temperature with high precision in air and other non-aggressive gases. They can be used for a wide range of applications.

The sensors in this series have got either a RS485-interface and are suitable for data transfer via MODBUS-RTU protocol or they have got a RS232-interface and are suitable for data transfer via ASCII protocol.

The transmitters with RS485-interface for data transfer of a MODBUS-RTU protocol are equipped with an hx processor that uses the values of the relative humidity and the temperature to calculate the dew point temperature, the enthalpy, the mixing ratio, the absolute humidity or the wet-bulb temperature, in accordance with the laws of physics ¹⁾.

All the sensors in this series are supplied with a ZE17-type gauze filter for sensors Ø 20mm or . We recommend to use a version with other filters (filter programme see product info sheet no. F 5.1) and a higher degree of protection if the sensor is used in meteorology, at high wind speeds or if the sensor is exposed to salt mist, sand or dust (near the sea, industrial estates etc.).

Technical Data

Humidity

sensing element	capacitive MELA FE09		
output range	0...100 %rh		
accuracy			
10...90 %rh	at 23°C		±1.5 %rh
< 10 %rh or > 90 %rh			±2 %rh
influence of temperature (ref. to 23°C)			<±0.02 %rh/K

Temperature

output ranges	active	-40...+85°C
accuracy (active) at 23°C		±0.2 K
influence of temperature (ref. to 23°C)		<±0.005 K/K

General data

measuring medium	air, pressureless, non-aggressive, non-condensing
min. air speed	0.5 m/s
operating temperature	-40...+85°C
storage temperature	-40...+80°C
degree of protection of measuring head	see product key
degree of protection connector	IP67
housing material	
	aluminium coated type IA..., IR..., Ø 20 mm
	stainless steel 1.4301 type IV..., IT..., Ø 15 mm

Electrical data

Voltage supply	5...30 V DC
max. transfer distance RS232/RS485	15m/1000m
consumption of electronics	< 1,95 mA
Directive about electromagnetic compatibility 2014/30/EU	
DIN EN 61326-1	issue 07/13
DIN EN 61326-2-3	issue 07/13

• Designs	rod-shaped sensor Ø 20mm or Ø 15mm with plug-in connection with robust connecting head
• Different physical outputs	humidity and temperature and all hx values ¹⁾
• Output signals	RS232 with ASCII protocol RS485 with Modbus RTU protocol
• Special versions	sealing against vibrations
• Different filters	see page 3

1) The accuracy of the calculated values depends on both the operating point in accordance with the hx diagram and on the primary values measured. The hx processor operates in the range -30°C < T < +70°C, 5% rh < F < 95% rh. Values outside this range are not calculated, the last valid value is displayed. Normal atmospheric pressure of 1013.25 mbar is used when calculating the hx values.

Accessories

Designation	Order reference	Info sheet	Description
Sub-D adapter cable for sensors with RS232 output	IAKR.02.67-02.5 (standard) Ready-made cable if required IAKR.02-67-xx.x IVKR.02-67-xx.x	-	connecting cable with binder plug and 9 pin SUB-D jack for direct connection to serial PC interface max. permissible ambient temperatures: binder plug and cable -40...+85°C / IP67 SUB-D jack (PC connection) -10...+50°C / IP30 (when connected) for Ø 20 mm 5 pin for Ø 15 mm 8 pin
Connecting cable for sensors with MODBUS output	(Ready-made cable if required) IAKM.02-67-xx.x IVKM.02-67-xx.x	-	connecting cable with binder plug, end of cable open with end sleeves for strands max. permissible ambient temperatures: -40...+85°C / IP67 <i>Electrical connections see p. 4</i> for Ø 20 mm 5 pin for Ø 15 mm 8 pin
USB adapter serial -> USB	as description	-	USB adapter for Sub-D-data line <i>To connect up the Sub-D-data line to a USB interface on the PC or Laptop</i>
Setup cable ModBus --> USB	IAKM.02.AK-01.8 IRKM.02.AK-01.8 IVKM.02.AK-01.8	-	Version with plug-in connection Ø 20 mm Version with robust head Version with plug-in connection Ø 15 mm to configure the modbus parameters and to adjust the sensors
ZA 161/1	as description	F5.1	weather guard for rod-shaped sensors <i>recommended for outside use to protect from rainfall and sunlight</i>
ZA 20	as description	F5.1	Attachment plate for sensors Ø 20 mm
ZA 24	as description	F5.1	Attachment plate for sensors Ø 15 mm
20.009	as description		Console for wall mounting Ø 20 mm
20.103	as description		Console for wall mounting including mounting sleeve 00.502 for sensors Ø 15 mm
ZE 31/1-12 ZE 31/1-33 ZE 31/1-75 ZE 31/1-84	as description	F5.2	humidity standard to check the accuracy of the sensors 12 %rh at 25°C humidity standard to check the accuracy of the sensors 33 %rh at 25°C humidity standard to check the accuracy of the sensors 75 %rh at 25°C humidity standard to check the accuracy of the sensors 84 %rh at 25°C
ZE33	as description	F5.2	adapter for humidity standard ZE 31/1

Dimensions

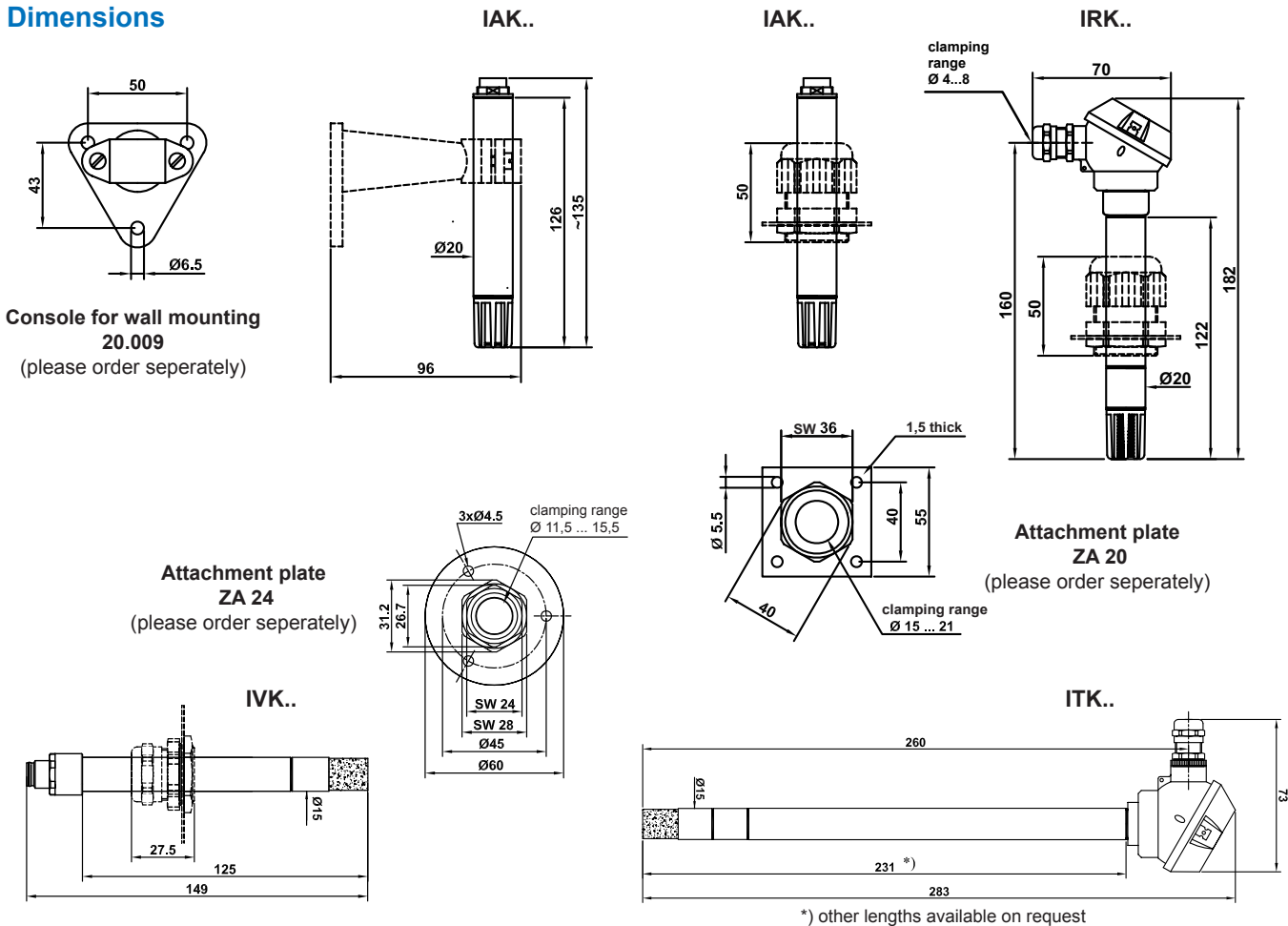

Product Key

Series	I Series	I
Design	tube Ø 20 mm alu with plug-in connection	A
	tube Ø 20 mm alu with robust connecting head	R
	tube Ø 15 mm stainless steel with plug-in connection	V
	tube Ø 15 mm stainless steel with robust connecting head of alu	T
Physical output	all humidity dependant values and temperature	K
	temperature only	T
Output signal	RS 232 ASCII protocol (only for design A and R)	R
	RS485 Modbus RTU protocol	M
Special edition	none	00
	sealing against vibrations	0V
	pressure proof up to 10 bar	0D
Measured value and output range 1	relative humidity and humidity dependant hx values	F1
	none	00
Measured value and output range 2	-40...85 °C	48
Operating voltage	5...30 V DC	5
Filter Ø 20mm	ZE16 protective plastic basket, open, IP30	16
	ZE17 protective plastic basket with gauze, IP30	17
	ZE18 fine-pored PTFE sintered filter, IP65	18
	ZE20 protective basket with membrane filter, IP54	20
	ZE21 fine-pored sintered filter of stainless steel, IP65	21
	ZE22 coarse-pored sintered filter of stainless steel, IP65	22
	PTFE filter for humidity sensing element + protective basket ZE16, IP30	9G
Filter Ø 15mm	ZE04 stainless steel filter, open, IP00	04
	ZE13 stainless steel sintered filter (standard), IP65	13
	ZE15 stainless steel sintered filter with gauze, IP30	15
	ZE26 stainless steel filter with PTFE membrane, IP54	26
	ZE29 sintered filter of fine-pored PTFE, IP65	29
	PTFE filter for humidity sensing element + protective basket ZE04, IP00	94
Type of connection and characteristics of design	5 pin plug-in connection (RS 232)	5S8
	7 pin plug-in connection (RS485 MODBUS 20mm Ø)	7S8
	8 pin plug-in connection (RS485 MODBUS 15mm Ø)	8S8
	Versions with robust head	00x ¹⁾

¹⁾ x= depends on the tube length

Ordering Example

IVKM.0V.F148.513.8S8

I Series (I),
 Stainless steel tube (V),
 Output of humidity dependant values and temperature (K),
 Output: RS485 with Modbus RTU protocol (M),
 Sealing against vibrations (0V),
 Relative humidity and all humidity dependant hx values (F1),
 -40...85°C (48),
 Operating voltage: 5...30 V DC (5),
 Sintered filter of stainless steel ZE13 (13),
 8 pin plug-in connection (8S8)

Working range for humidity and temperature

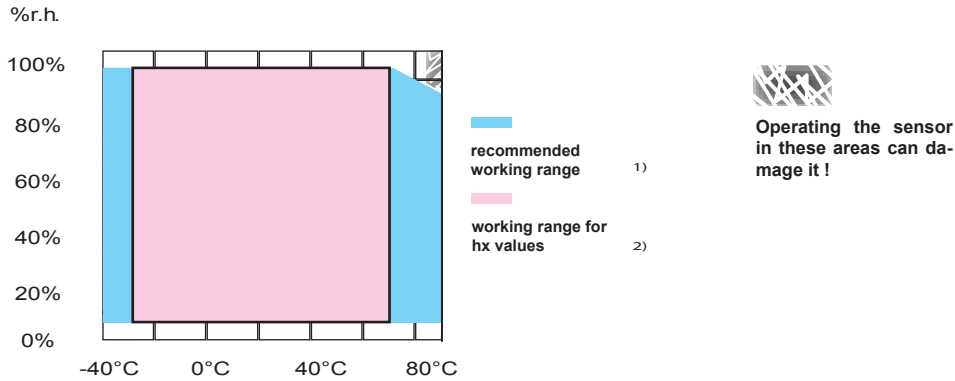

- 1) In continuous operation mode, the elements should be used up to an absolute humidity level which corresponds to a dew-point temperature not exceeding 60°C. The elements can be used at dew-point temperatures of up to 90°C during short work cycles (e.g. in a control process).
- 2) The hx processor operates in the range $-30^{\circ}\text{C} < T < +70^{\circ}\text{C}$, $5\% \text{ rh} < F < 95\% \text{ rh}$. Values outside this range are not calculated, the last valid value is displayed

Mounting and user information

Position	<p>The installation site should be chosen such that a representative measurement of air humidity can be guaranteed. Avoid areas in the vicinity of radiators, doors and exterior walls, as well as direct sunlight.</p> <p>The position the sensor is mounted in (horizontal, vertical) does not matter. However, it should be mounted in such a way that no water can get into it. We recommend that you lay the connection lines in a loop so that any water that may be present can run off.</p> <p>Please note the maximum permissible ambient temperature when installing the sensor. The sensors always have to be installed in such a way that the plugs are not exposed to an increased ambient temperature either ($>85^{\circ}\text{C}$).</p>
Connection	<p>The electrical connection must be carried out by qualified personnel only.</p> <p>The sensors of the I series contain components, which can be damaged by the effects of electrical fields or by charge equalisation when touched. When mounting the sensor, protective measures must be taken.</p> <p>Lines to and from the sensor must not be installed parallel to strong electromagnetic fields. If there is any chance of an electrical surge, please install surge protection devices.</p>
Dew formation	<p>Dew formation and splashes do not damage the sensor, although corrupted measurement readings are recorded until all the moisture on and directly around the sensor element has dried up.</p>
Dust	<p>Dust and other solid particles do not damage the humidity sensor element, however, if there is an accumulation of dust on it, the dynamic behaviour could be impaired.</p>
Cleaning the filters	<p>Contaminated filters and protective baskets can be carefully unscrewed for cleaning. Do not refit the filter attachment unless it is completely dry, to avoid measuring errors. Take care not to touch the sensitive humidity sensor element.</p> <p>Please note that the sensor is only able to measure accurately once the filter and the sensor element are fully dry.</p>
Cleaning the sensing element	<p>Loose dirt can be removed from the moisture sensor element by careful blowing or rinsing with distilled water. Take care not to touch the sensitive humidity sensor element.</p>
Damaging influences	<p>Depending on their type and concentration, aggressive media containing solvents can cause incorrect readings or cause the sensor to fail.</p> <p>Substances deposited on the sensor element (e.g. fats, oils, resin aerosols, paint aerosols, smoke deposits etc.) are harmful as they eventually form a water-repellent film or deteriorate the dynamic behaviour of the sensor. This also applies for the contamination of the PTFE filter for the sensing element (9G) with these substances.</p>
Check functioning	<p>In order to check functioning in the place of installation, we recommend that you use our <i>ZE31/1-x type humidity standards</i> (accessories).</p>

Connection diagrams RS485 ModBus

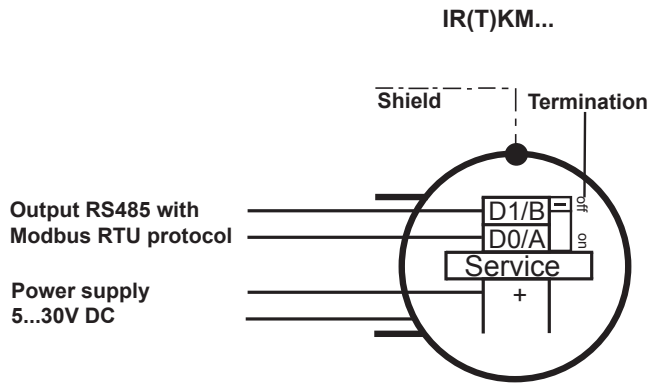

Order reference cable for sensors with plug-in connection and ferrules (optional)

IyKM.02.67-xx.x ---> with coupling IP67

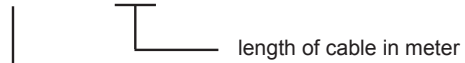

- A ---> for sensors with plug-in connection Ø 20 mm
- V ---> for sensors with plug-in connection Ø 15 mm

Order reference for setup cable ModBus sensors (optional)

IyKM.02.AK-01.8

- A ---> for sensors with plug-in connection Ø 20 mm
- R ---> for sensors with robust head
- V ---> for sensors with plug-in connection Ø 15 mm

IAKM...

Pin	Designation
1	Service
2	D0/A/Data
3	D1/B/Data
4	Vcc
5	GND
6	Service
7	Termination*

* optional

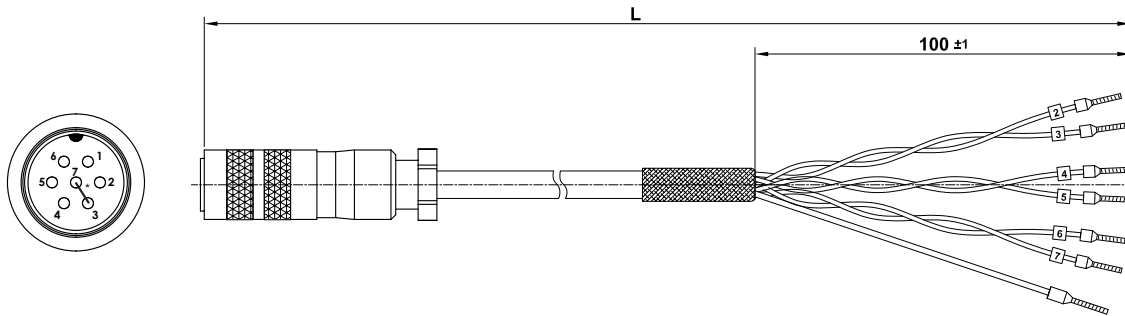
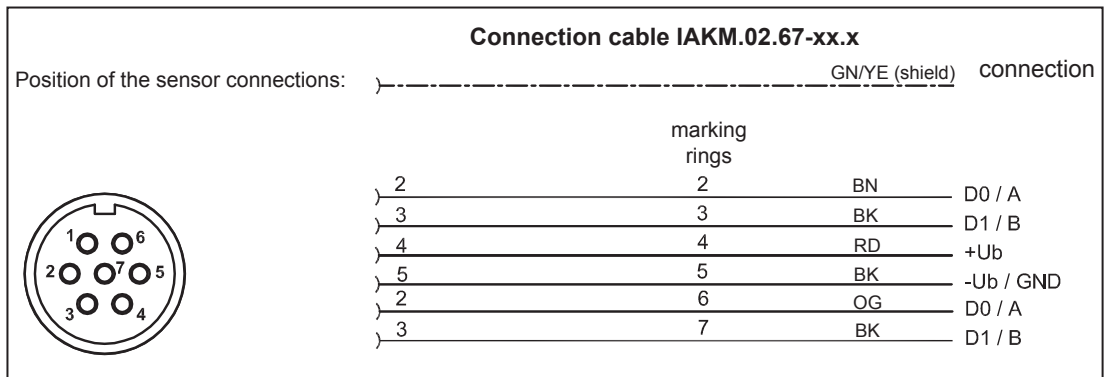

IVKM...

Pin	Designation
1	D0/A/Data
2	Service
3	Service
4	D0/A/Data
5	D1/B/Data
6	GND
7	D1/B/Data
8	Vcc

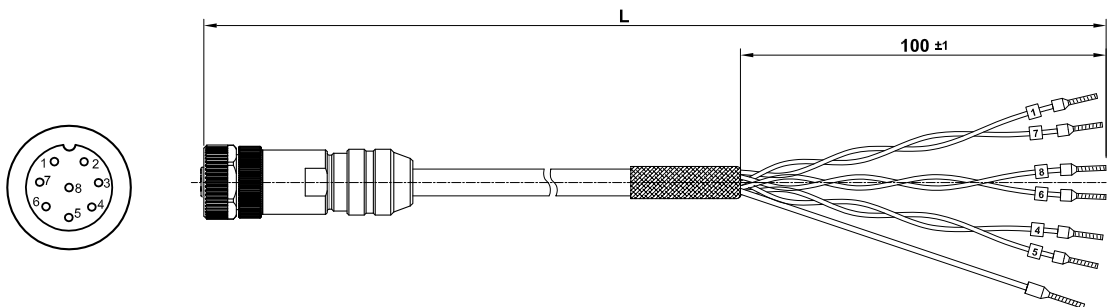
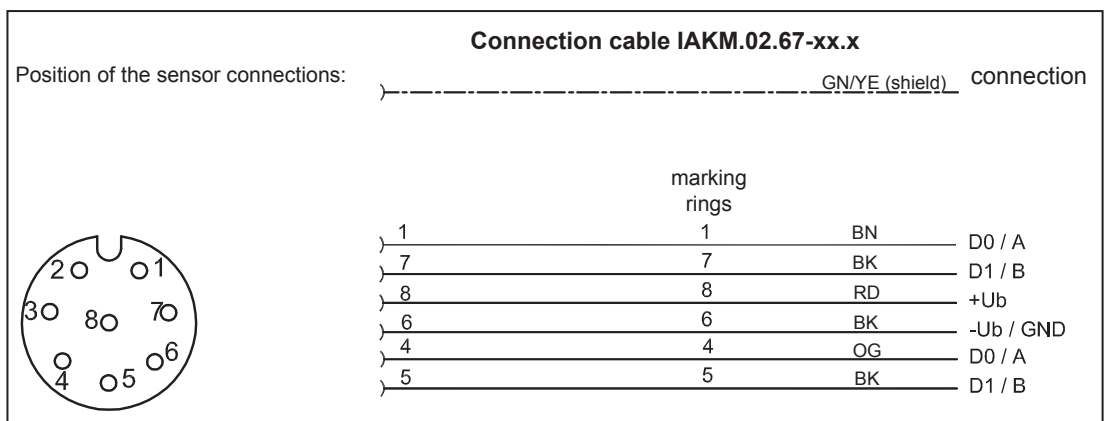

RS485 with MODBUS-RTU Protocol

Serial interface

The following parameters are possible for data transfer via the EIA-485 interface on the ModBus sensors made by Mela®:

- Baud rate: 19200 / 9600 / 4800 / 2400 / 1200 / 600
- Data bits: 8
- Parity: N / E / O
- Stop bits: 1 / 2

Modus 19200@8N2 is pre-defined.

Access to Modbus registers

To ensure compatibility with all Modbus masters, all available registers can be read both with function code 03_{hex} (read holding register), as well as with function code 04_{hex}. Registers with additional write permission can be modified with function code 06_{hex} (write holding register). All registers available with Modbus sensors by Mela are listed in table 1.

Register-no.	Data type	Value	Permission
0	FLOAT32	Temperature (°C)	readable
1			
2	UINT16	Alarm code temperature	
3	FLOAT32	Relative humidity (%rH)	
4			
5	UINT16	Alarm code humidity	
6	UINT32	Serial number sensor	
7			
8	UINT32	Serial number sensor	
9			
10	FLOAT32	Dew point temperature (°C)	
11			
12	FLOAT32	Enthalpy (kJ/kg)	
13			
14	FLOAT32	Mixing ratio (g/kg)	
15			
16	FLOAT32	Absolute humidity (g/m³)	
17			
18	FLOAT32	Wet-bulb temperature (°C)	
19			
20	UINT16	Alarm code hx processor	
205	UINT16	Modbus address	read and writeable

Table 1 - Modbus register

Functioning

The measured values for relative humidity, temperature and the corresponding alarm codes are saved in registers 0...5 in a cycle time of 2s. Registers 6(8) and 7(9) contain the sensor's serial number. If an hx value is scanned from registers 10...19, this is recalculated at the time of the scan, based on the current temperature and the relative humidity. The hx processor emits an alarm code if the values for temperature or relative humidity are outside the permissible input range. No calculation is made in this case, and the register displays the last valid value for each variable.

The memory organisation for the temperature and air humidity readings, as well as for the serial number, is Little Endian. This means that the low byte word is in the lower register and the high byte word is in the higher register.

Alarm codes

Table 2 lists all the possible alarm register values when measuring temperature (reg. no. 2).

Alarm code	Meaning
0	no alarm, the temperature value is within the limits
1	temperature range of the measuring head exceeded
2	below temperature range of the measuring head
3	Wire break or no sensor element detected
4	short circuit at PT1000 (resistance < 500 Ohm)

Table 3 lists all the possible alarm register values when measuring humidity (reg. no. 5).

Alarm code	Meaning
0	no alarm, the humidity value is within the limits
1	humidity range of the measuring head exceeded
2	below humidity range of the measuring head
3	Wire break or no sensor element detected
4	humidity element defective

Table 4 lists all the possible alarm register values of the hx processor (reg. no. 20).

Alarm code	Meaning
0	no alarm, input values are within the limits
1	max. input value of humidity 95%rh and/or temperature +70°C is exceeded
2	min. input value of humidity 5%rh and/or temperature -30°C is below limit

The Modbus address can be modified at any time via write access to the address register (reg. no. 205). Permissible slave addresses are within the 1...247 range. Using address 0 as a slave address is not permissible. Addresses within the 248...255 range are reserved for special Modbus services and their use as a slave address is not permissible either. Address 1 is pre-defined.

Configuration of Modbus parameters

In standard mode (and in the network if required), the Modbus address for all sensors can be modified by entering an appropriate write command. The write command will still be acknowledged using the old address. The sensor can then be accessed immediately via the new address.

Further configuration of Modbus parameters, such as address, baud rate, parity and stop bits is only possible with a suitable setup cable for the relevant sensor type (see accessories on p. 2). These settings are then made from a PC via the **ModSens-Setup** software available for download. For this, the sensors must not be in the network.

The **ModSens Setup** software is available on our Homepage as a free download

Operation

To connect directly to a PC, all you need is an integrated RS485 interface or an external adaptor. Mains power can also often be supplied in this way. A software program such as Modbus Poll will then assume the role of the master

Further measures must be taken for more challenging applications in the network, for long distances and/or in environments with electromagnetic interference. The bus must be designed in a daisy chain structure without spurs. For this reason, any cables connected to the sensors have a double data line pair – one incoming and one outgoing. The data line must be designed as a screened and twisted pair. The first and the last bus nodes must be terminated. If DC termination is sufficient, the integrated resistance of 135Ω can be switched between A and B – provided this is available on the relevant model. To do this, switch the jumper in the appliance to the corresponding position or bridge the corresponding pins in the connector. If you have to use transmission line polarisation, we advise against using DC termination. Instead you should use AC termination. The required series connection for the resistor and the capacitor can then be switched between A and B on the second data line pair of the connection cable or on the second terminal pair in the terminal block.

A Mela Modbus sensor according to the RS485 standard represents 1/8 unity load. If the network only contains sensors in this impedance category, 256 bus nodes are theoretically possible instead of 32. However, due to the available address space, in practice the number reduces to 247.

The scanning interval should not exceed 2 seconds across the entire network.

For further information see <http://www.modbus.org/> .

Aligning the sensors

The sensors can also be aligned, thing which is made from a PC using the **UserCalib-Wizard** software, which is available as a free download. When doing so the sensors should not be in the network.

To connect the sensors to a PC you need the same cable set as described in „configuration of modbus parameters“.

The **UserCalib-Wizard** software is available on our Homepage as a free download

„UserCalibWizzard“ calibration and adjustment software

This software is a PC application for Windows which can be used to calibrate and adjust I series sensors easily.

The program is designed as a wizard with simple navigation to guide users through the required steps to adjust sensors, verify measurements digitally, save data and print results. Required reference values can be obtained from a sensor used as reference, or entered directly at all measurement points.

Connecting the sensors to the PC requires a suitable setup cable (lyKM.02.AK-01.8) which is available from Pedak (see accessories on p. 2).

RS232 with ASCII Protocol

Serial interface

The data transfer via the RS232 interface is effected with the following parameters:

- Baud rate: 9600
- Data bits: 8
- Parity: N
- Stop bits: 1

If power is also supplied to the sensor via the interface, the RTS and DTR signals must also be permanently enabled.

ASCII protocol

Approximately every 3 seconds (approx. 5 sec in case of an error), the sensor transmits a character string containing the measured values for relative humidity, temperature and the corresponding alarm codes and serial numbers. A checksum ensures the validity. The output character string has a constant length of 41 characters in the following format:

@T;<Sign>;<Temperature>;<Alarmcode>;F;<Humidity>;<Alarmcode>;<Serialnumber>;<Sum>\r\n

The individual characters and fields have the following meanings:

„@“	Begins a protocol frame
„T“	Marks the temperature value
„F“	Marks the humidity value
„,“	Separator
„\r“	Carriage Return
„\n“	Line Feed
<Sign>	Temperature plus/minus sign, „+“ or „-“
<Temperature>	5 characters, two integer places, two decimal places from „0“ ... „9“, Comma symbol is „,“
<Alarmcode>	3 characters, „A00“ ... „A04“
<Humidity>	6 characters, three integer places, two decimal places from „0“ ... „9“, comma symbol is „,“
<Serialnumber>	8 characters from „0“ ... „9“
<Sum>	2 characters from „0“ ... „9“ or „A“ ... „F“

Examples:

- 1: @T;+021.37;A00;F;038.92;A00;12345678;38\r\n
- 2: @T;+018.97;A00;F;099.54;A00;00251979;0A\r\n

Table 1 lists all the possible values when measuring temperature

Alarm code	Meaning
A00	No alarm, the temperature value is within the limits
A01	Temperature measuring range of the measuring head exceeded
A02	Below temperature measuring range of the measuring head
A03	Wire break or no sensor element detected
A04	Short circuit at PT1000 (resistance < 500 Ohm)

Table 2 lists all the possible values when measuring humidity

Alarm code	Meaning
A00	no alarm, the humidity value is within the limits
A01	humidity range of the measuring head exceeded
A02	below humidity range of the measuring head
A03	Wire break or no sensor element detected
A04	humidity element defective

The sum is calculated according to the following algorithm with reference to example 1:

1. Add up the decimal representation of all ASCII characters from “@” to the final “;”
 $64 (,@) + 84 (,T) + 59 (,;) + 43 (,+) + 48 (,0) + 50 (,2) + \dots + 54 (,6) + 55 (,7) + 56 (,8) + 59 (,;) = 1991$
2. Divide this sum by 256 to find the remainder
 $1991 \% 256 = 199$
3. Subtract the remainder from 255
 $255 - 199 = 56$
4. Interpret the decimal result as a hexadecimal number
 $56 = 38_{\text{hex}}$
5. Compare the individual hexadecimal numbers with the transmitted ASCII characters of the checksum
 $38_{\text{hex}} \rightarrow \text{„3“} \& \text{„8“} \checkmark$

Connection diagrams RS232

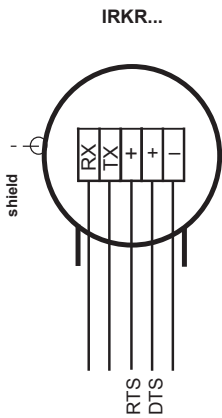

Only applicable for direct connection to a PC

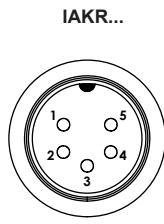

Pin	Designation
1	(Vcc)
2	RxD
3	TxD
4	Vcc
5	GND

Order reference cable for sensors with plug-in connection and ferrules (optional)

IAKR.02.67-xx.x ---> with coupling IP67

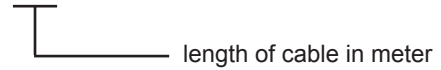

**SUB-D adapter cable 2.5m standard (IAKR.02.67-xx.x), customised on request, max. 15 m (accessory)
Output: RS232**

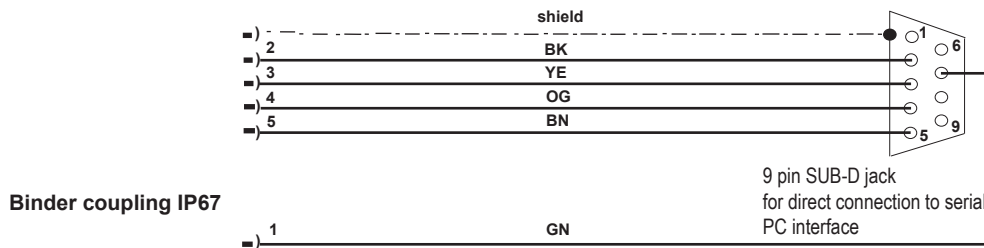

VisualPMU Freeware for RS232

This simple and very clear visualisation software supports the data output of a sensor via a serial interface on the PC or laptop without an additional power supply.

To use this, it is necessary to install the accessory *Sub-D data line* (refer to accessories and connection diagrams). For USB connections, a *USB adapter* can be supplied (see accessories).

The relative humidity, the dew point and the temperature (°C or °F) can be displayed and can be depicted as a graph.

Apart from that, the programme has a simple data logger function. Recorded data can be exported to other programmes.

This freeware version can be found on our Homepage as a free download

This information is based on current knowledge and is intended to provide details of our products and their possible applications. It does not, therefore, act as a guarantee of specific properties of the products described or of their suitability for a particular application. It is our experience that the equipment may be used across a broad spectrum of applications under the most varied conditions and loads. We cannot appraise every individual case. Purchasers and/or users are responsible for checking the equipment for suitability for any particular application. Any existing industrial rights of protection must be observed. The quality of our products is guaranteed under our General Conditions of Sale. Data sheet I-Serie_digital. Issue: September 2017. Subject to modifications