



Room Hygrostat

with Polyga®- humidity measuring element **HGMini**
with adjusting knob inside the housing **HGMini-i**

Application

The hygrostat type **HG Mini** is used as an on-off controller to control the relative air humidity. It can be used to control air humidifiers and dehumidifiers in offices and computer rooms. Other areas of use are storage of foodstuffs and luxury foods, cooling rooms for fruit and vegetables, greenhouses for gardening use, the textile industry, the paper and printing industry, the film industry and hospitals. The hygrostats can be used almost anywhere that air humidity has to be regulated or monitored.

The room hygrostat **HG Mini-i** is designed so that the adjusting knob and the scale are inside the housing. This makes unauthorized manipulation by third parties more difficult.

Description of the hygrostat

The humidity measuring element, produced by Galltec under the name Polyga®, consists of several synthetic fabric bands each with 90 individual fibres with a diameter of 3µm. A special process gives the fibre hygros-copic properties. The measuring element absorbs and desorbs humidity. The swelling effect, which is predominantly in a lengthways direction, is carried via a suitable lever system to a microswitch with an extremely small switching path. The measuring element reacts quickly and precisely to the change in air humidity. By adjusting the setpoint value control knob, the lever system is engaged so that when the set air humidity is reached the microswitch is activated.

The fan-shaped measuring element is accommodated inside the housing and must be protected against coarse dust, dirt and water. The sensors are designed for pressureless systems. The mounting position should be chosen such that condensed water cannot get into the interior of the housing. Any mounting position is possible, preferably with ventilation slots across the direction of wind.

Technical Data

scale range 30...100%rh
measuring accuracy ±3%rh
range of operation 35...95%rh
switching difference (microswitch) ref. to 50%rh
..... approx. 4%rh

breaking capacity

max. 250VAC and

0,1 ... 5A ohmic load for dehumidifying

0,1 ... 2A ohmic load for humidifying

0,1 ... 1A for inductive load with $\cos \varphi = 0,7$

lifetime 100.000 breaking cycles

Please observe the notes on voltage.

optional microswitch with gold contact

breaking capacity

max. 48 VAC and

1...100 mA

allowable ambient temperature 0...60°C

medium temp. coefficient -0.2%/K rel.to 20°C and 50%rh

allowable air speed 15m/sec

half-life period at v=2m/sec 1.2min

fixing slots in housing base

mounting position optional, preferably ventilation slots at

right-angles to wind direction

contacting connecting terminal in the case

electromagnetic compatibility

directive 2006/95/EG

applied standards

DIN EN 60730-1 issue 12/05

DIN EN 60730-2-13 issue 09/02

housing solid plastic, light grey

protective system IP20

measuring element

.....Polyga®-measuring element, water resistant

dimensions85x55x36mm

weight approx. 0.06 kg

Type Survey

Type	Order no.	Type of contact
HGMini	42042017	changeover contact: 1 x max. 5 A
HGMini-i	42042018	changeover contact: 1 x max. 5 A with internal scale
HGMini	42047017	changeover contact (gold plated): 1 x max. 100 mA
HGMini-i	42047018	changeover contact (gold plated): 1 x max. 100 mA with internal scale
HGMini	42047017 00000110	changeover contact (gold plated, IP67): 1 x max. 100 mA

Dimensions diagram

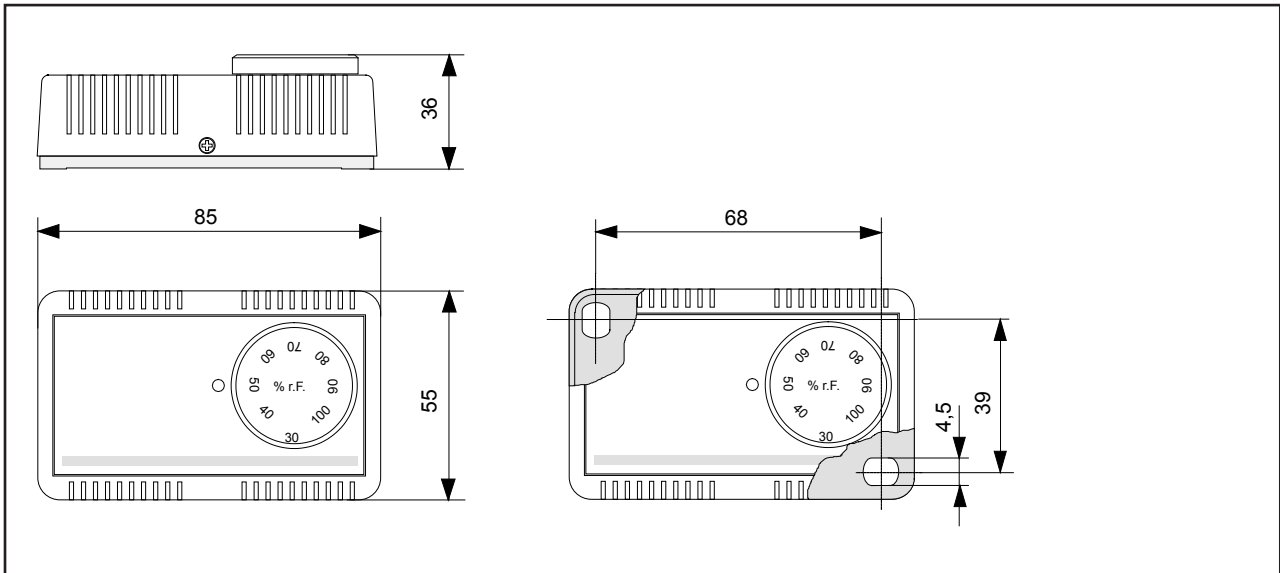

Slot diagram

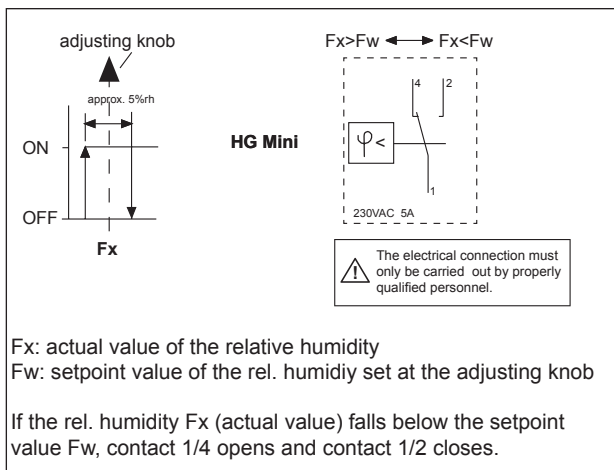

Mounting

- The hygrostat must not come into direct contact with water, e.g. splashed water when cleaning the climatic chamber etc.
- The mounting location should be chosen so that a representative measurement of the air humidity can be guaranteed, i.e. the humidity readings at the mounting location should correspond to those in the room.
- The hygrostat should be exposed to the flow of air.

Notes on voltage

The measurement location of the humidity controller should be selected such that there is no build-up of condensate on or in the device. This applies particularly for operation with a voltage higher than 48V. If the voltage is higher, there is a risk of voltage arcing in the event of water condensation on the microswitch or connecting terminals which might destroy the controller. In the case of voltage below 48V, the humidity controller can be used up to 100%rh.

Maintenance

The measuring element is maintenance-free in pure ambient air. Aggressive media containing solvent can cause measuring errors and failure, depending on the type and concentration. As with almost all humidity measuring elements, deposits which eventually form a water-repellent film over the measuring element are harmful (such as resin aerosols, lacquer aerosols, smoke deposits etc.).

NOTE:

Contact with the inner parts nullifies the guarantee.

Physical influence of temperature on the relative air humidity

at a temperature fluctuation of ±1K referred to various room temperatures.

	10°C	20°C	30°C	50°C
10%rh	+/-0,7%rh	+/-0,6%rh	+/-0,6%rh	+/-0,5%rh
50%rh	+/-3,5%rh	+/-3,2%rh	+/-3,0%rh	+/-2,6%rh
90%rh	+/-6,3%rh	+/-5,7%rh	+/-5,4%rh	+/-4,6%rh

It is thus of extreme importance that the temperature is constant for measurements of the relative air humidity. The air must be homogenous.