



**Versions :**

**PascaMaxx 500 Z : P/N 260 0091**

Meas. range : 0...500 Pa (unidirectional)

Power supply : 24VDC

Signal output : 0/4...20mA, 0/2...10V

Relay : 230V, 2A

**PascaMaxx 2000 Z : P/N 260 0083**

Meas. range : 0...2000 Pa (unidirectional)

Power supply : 24VDC

Signal output : 0/4...20mA, 0/2...10V

Relay : 230V, 2A

# PascaMaxx

## DIFFERENTIAL PRESSURE MEASUREMENT INSTRUMENT FOR FILTER-SYSTEMS, VENTILATORS, FLAP-CONTROLS

### General information

The PascalMaxx differential pressure measurement instrument has been developed for the monitoring of filter systems, ventilators and flap-controls in centralised air conditioning plants. Thanks to the integrated automatic zero-point calibration system, the device enables very accurate and stable measurements. A big, clear LCDisplay facilitates the value reading.

The instrument settings are done by the front side buttons through the user friendly and intuitive user menu. The PascalMaxx can be easily configured for different applications. The range of products consists of 2 versions, with measurement range 0 to 500 Pa or 0 to 2000 Pa. A robust housing and the optional dust protection filters allow an ideal use in the air conditioning industry.

The automatic zero-point calibration system makes adjustments unnecessary and thus reduces operation and maintenance costs. Furthermore it allows a mounting irrespective of its position.

Together with the analogue output also a relay is integrated in the system for an automatic alarm or 2-point control purpose. Nominal values, hysteresis and delay can be set through the device's user menu.

The instrument functions are continuously monitored and eventual failures are indicated immediately on the LCDisplay.

The PascalMaxx disposes not only of outstanding measurement features and functions but also of a unique cost efficiency.

### Features

- Unique cost efficiency
- Ergonomic design
- Big, clear LCDisplay
- Easy calibration features at 2 points
- 2 programmable alarm thresholds for 2-point control
- Intuitive menu structure
- Scalable, analogue output & 1 relay
- Password protection
- Automatic zero-point calibration
- Filter function for display and analogue output
- Integrated dust particle protection filter
- SWISS-MADE Quality

### Applications

- Measurement, monitoring and control of air conditioning plants and industrial processes :
- Industrial HVAC (Heating, Ventilation, Air Conditioning) plants for processes
  - Clean Room applications
  - Tunnels and underground mining
  - Air lock systems
  - DDC-, PLC- or discrete control systems

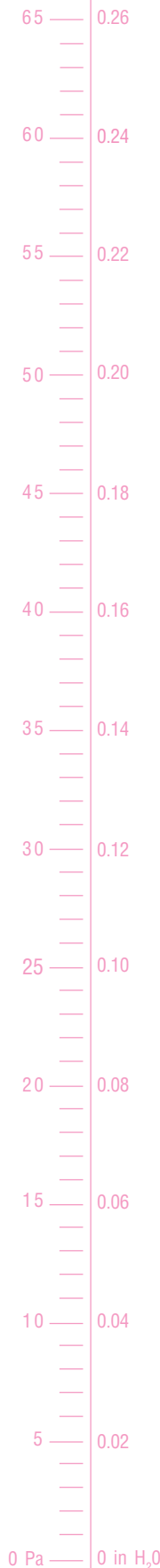

## Technical data

| Type  | PascaMaxx 500 Z                                       | PascaMaxx 2000 Z             |
|---|---|------------------------------|
| Part no.  | <b>260 0091</b>                                       | <b>260 0083</b>              |
| Dimensions  | 110 x 130 x 50 mm                                     | 110 x 130 x 50 mm            |
| Measurement range differential pressure (fresh air) | 0 ... 500 Pa  | 0 ... 2'000 Pa               |
| Max. resolution                                     | 0.1 Pa  | 1 Pa                         |
| Accuracy  | +/- 1.0 %   | +/- 0.5% (of the full scale) |
| Temperature effect                                  | < +/- 0.2 Pa/°C                                       |                              |
| Differential pressure sensor                        | Piezo resistive membrane                              |                              |
| Max. permissible overpressure                       | +/- 35'000 Pa   |                              |
| Operating temperature                               | 0 ... + 50°C  |                              |
| Long term stability / drift                         | < 2 Pa / year (automatic zero-point calibration)      |                              |
| Power supply  | 19.2 ... 28.8 VDC (In-Out without galvanic isolation) |                              |
| Power consumption                                   | max. 2.5 Watt (in operation)                          |                              |
| Outputs :   | Ranges scalable individually                          |                              |
| Analogue output                                     | 0 ... 10V / 2 ... 10V / 0 ... 20 mA / 4 ... 20 mA     |                              |
| Relay output  | max 230 VAC - 2A ohmic (adjustable)                   |                              |
| Norm tests :  |   |                              |
| Electromagnetic compatibility                       | EN 61326-1 / EN 61326 A1                              |                              |
| IP-protection                                       | IP 41   |                              |
| Storage temperature                                 | -10 ... +60 °C (not condensing)                       |                              |
| Measurement medium                                  | dry, not condensing, not aggressive gases             |                              |



## Accessories + Spare parts

|   | Part no.        |
|---|-----------------|
| External power supply EUR plug 90...260 VAC   | <b>252 4210</b> |
| External power supply US/JP plug 90...260 VAC | <b>252 4211</b> |
| Spare plug set                                | <b>260 0096</b> |
| Protection filter set                         | <b>260 0097</b> |
| Factory calibration with certificate          | <b>111 7603</b> |

Application filter monitoring :

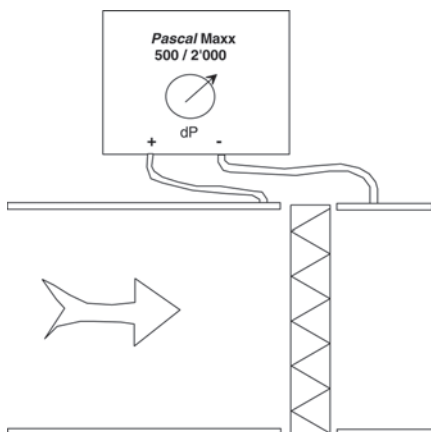

Electrical connection PascalMaxx :

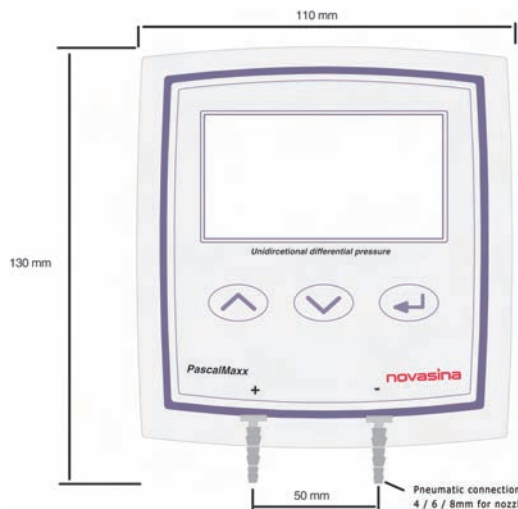
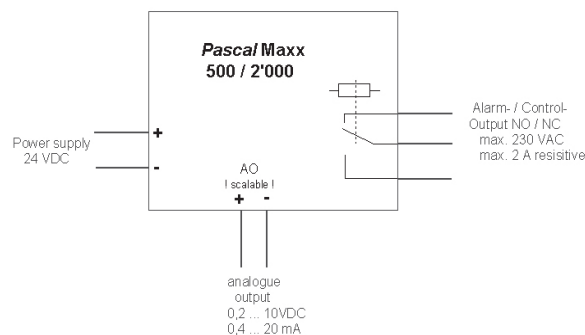

PascalMaxx 500 / 2000 Z

Subject to change without notice !