

More Precision.

optris[®] CT laser 1M/ 2M

Non-contact temperature measurement with precise aiming from 250°C to 1800°C



FEATURES

- Accurate temperature measurements of metals, secondary metal processing and ceramic materials
- Double laser aiming marks real spot location at any distance
- Optical resolution up to 330:1 with selectable focus
- Temperature ranges from 250°C to 1800°C, measuring spots up from 0.45 mm and response times up from 1ms
- Usable up to 85°C ambient temperature without cooling and automatic laser switch off at 50°C
- Short measuring wave length of 1 μm or 1.6 μm reduces error of temperature readings on surfaces with low or unknown emissivity

General specifications	
Environmental rating	IP 65 (NEMA-4)
Ambient temperature	sensing head: -20 - 85°C (50°C with laser ON) electronics: 0 - 85°C
Storage temperature	sensing head: -40 - 85°C electronics: -40 - 85°C
Relative humidity	10 - 95 %, non condensing
Vibration (sensor)	IEC 68-2-6: 3 G, 11-200 Hz, any axis
Shock (sensor)	IEC 68-2-27: 50 G, 11 ms, any axis
Weight	sensing head 600 g electronics 420 g
Electrical specifications	
Outputs/analog	channel 1: 0/4 - 20 mA, 0 - 5/10 V, thermocouple J, K channel 2: sensing head temperature (-40 - 85°C as 0 - 5 V or 0 - 10 V), alarm output
Optional:	relay: 2 x 60 V DC/42 V AC _{eff.} 0.4 A; optically isolated
Outputs/digital (optional)	USB, RS232, RS485, CAN, Profibus DP
Output impedances	mA max. 500 Ω (with 5 - 36 V DC) mV min. 100 k Ω load impedance thermocouple 20 Ω
Inputs	programmable functional inputs for external emissivity adjustment, ambient temperature compensation, trigger (reset of hold functions)
Cable length	3 m (standard), 8 m, 15 m
Current draw	max. 160 mA
Power supply	8 - 36 V DC
Laser 635 nm	1mW, ON/OFF via electronic box or software

Measurement specifications	
Temperature range (scalable via programming keys or software)	485 - 1100°C (1ML) 650 - 1800°C (1MH) 250 - 800°C (2ML) 385 - 1600°C (2MH)
Spectral range	1 μm (1M) 1.6 μm (2M)
Optical resolution (90% Energy)	150:1 (1ML, 2ML) 330:1 (1MH, 2MH)
System accuracy ¹⁾ (at ambient temperature 23 \pm 5°C)	\pm (0.3% of reading + 2°C)
Repeatability (at ambient temperature 23 \pm 5°C)	\pm (0.1% of reading + 1°C)
Temperature resolution (NETD)	0.1°C
Response time (90% signal)	1 ms
Emissivity/Gain (adjustable via programming keys or software)	0.100 - 1.100
Transmissivity/Gain (adjustable via programming keys or software)	0.100 - 1.000
Signal processing (parameter adjustable via programming keys or software, respectively)	peak hold, valley hold, average; extended hold function with threshold and hysteresis

¹⁾ E = 1, response time 1s

optris® CT laser 1M/ 2M

Optical specifications

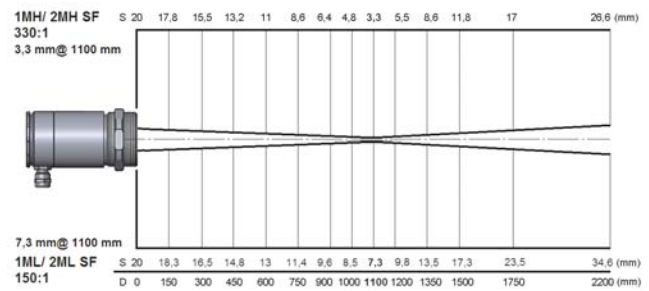
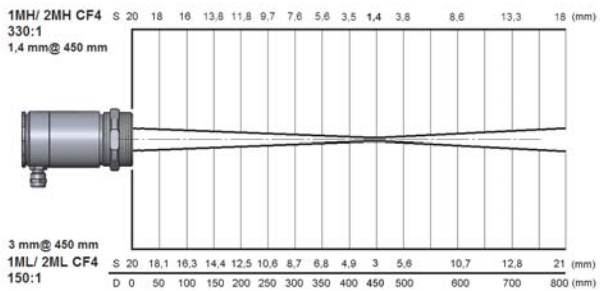
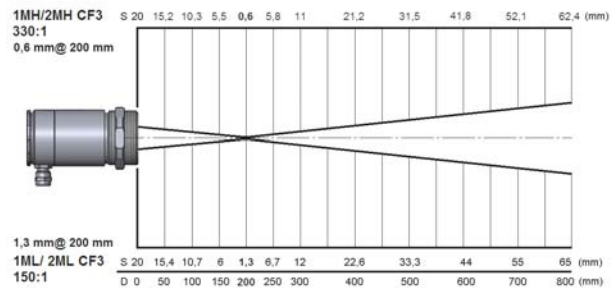
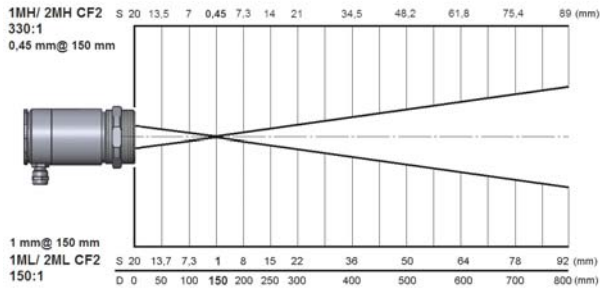

Dimensions

Sensing head

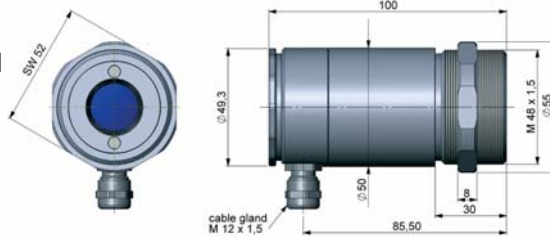

Electronics

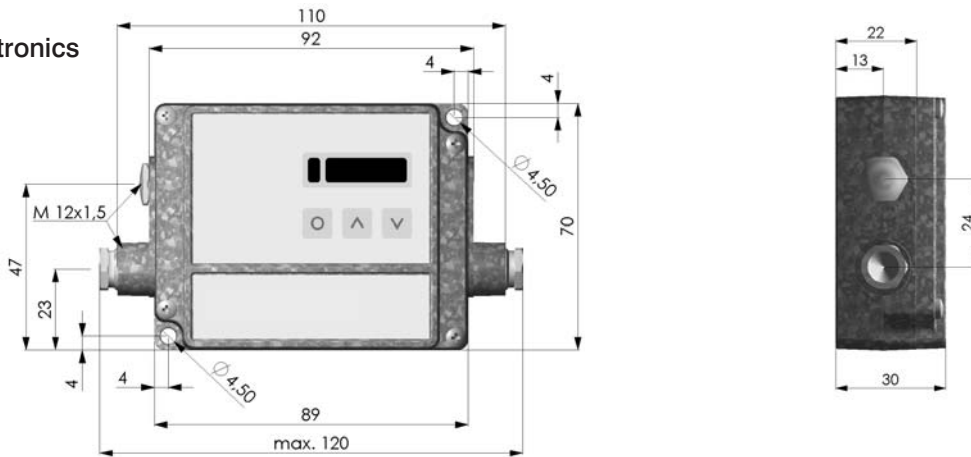

CompactConnect Software

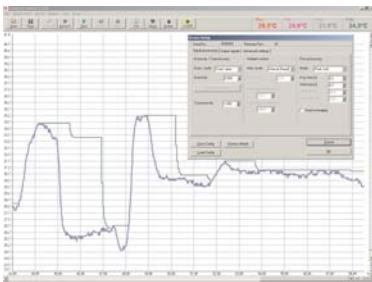

- Software for easy sensor setup and remote controlling, supports multi tasking
- Graphic display for temperature trends and automatic data logging for analysis and documentation with 1 ms response time
- Adjustment of signal processing functions and programming of outputs and functional inputs of the sensor
- Automatic emissivity adjustment
- The software CompactConnect allows to customize the sensor to application needs of the user