

Produktinfo Nr. B 1.4 humidity sensing modules

Description

The MELA[®]-*sensing modules* are sub-assemblies which are used to measure relative humidity, relative humidity and temperature, and temperature in air and other non-aggressive gases.

The MELA[®]-*sensing modules* are available as printed circuit board installation modules (OEM modules). With the wide range of types, these modules can be used for a wide range of applications.

We recommend „F“ and „C“-type modules, with an output signal of 0...1 V, for battery-powered devices because of their extremely low induced current requirements.

The sensing modules of the GM../5 series come with a ZE17 type protective basket, those of the VM../5 series come with a ZE13-type protective basket.

Series GM../9, VM../9 resp. OM../9 is equipped with an integrated PTFE filter. The advantages are its improved dynamics, in particular at low air speeds and also its increased service life, even under more challenging operating conditions (pollutant impact or permanent humidity >95 %rh). When air speeds are extremely high combined with a high number of particles, using the series ../9 is not recommended.

With the series ../9 it is not possible to exchange the protective baskets ZE16 or ZE14 with other filters.

Technical Data

Humidity

measuring range 0...100%rh
accuracy (5...95%rh at 10...40°C) ±2%rh
influence of temp. <10°C, >40°C <0.1%/K additional

Temperature

measuring element (ref. DIN EN 60751) Pt100 cl.B
measuring range temperature -30...+70°C
class 1/3 DIN on request
accuracy 0...1V (-27... 70°C) ±0.2 K
0...10V (-29... 70°C) ±0.2 K
4...20 mA ±0.3K
influence of temp. <10°C, >40°C ±0.007K/K additional

Other data

ambient temperature -40°C...+80°C
power consumption 0...10V, 2x 0...1V <5mA
0...1V <1mA
minimum air speed (across the sensor)
output 0...10V, 2x 0...1V ≥0.5m/s
4...20mA, 2x 0...10V ≥1m/s
2x 4...20mA ≥1.5m/s
load resistance (voltage output 0...10V/0...1V) ... ≥10kΩ/≥2kΩ
load (current output) acc. diagram
operating voltage
current output 12...30V DC
voltage output 0...10V 15...30V DC
voltage output 0...1V 6...30V DC

self-heating Pt100 (v=2 m/s in air).....0.2 K/mW

„subject to technical modifications“

Type versions measured variable	output	OM series printed circuit board	GM series alu tube with thread	VM series stainless steel tube with thread
F relative humidity	0...20 mA	FOM4/x	FGM4/x	FVM4/x
	4...20 mA	FOM3/x	FGM3/x	FVM3/x
	0...10 V	FOM2/x	FGM2/x	FVM2/x
	0...1 V	FOM1/x	FGM1/x	FVM1/x
C rel. humidity + temp. passive	0...20 mA+Pt100	COM4/x	CGM4/x	CVM4/x
	4...20 mA+Pt100	COM3/x	CGM3/x	CVM3/x
	0...10 V+Pt100	COM2/x	CGM2/x	CVM2/x
	0...1 V+Pt100	COM1/x	CGM1/x	CVM1/x
K rel. humidity + temp. active	2 x 4...20 mA	KOM3/x	KGM3/x	KVM3/x
	2 x 0...10 V	KOM2/x	KGM2/x	KVM2/x
	2 x 0...1 V	KOM1/x	KGM1/x	KVM1/x
T tempera- ture	Pt100	TOM5/5	TGM5/x	TVM5/5
	4...20 mA	TOM3/5	TGM3/x	TVM3/5
	0...10 V	TOM2/5	TGM2/x	TVM2/5
	0...1 V	TOM1/5	TGM1/x	TVM1/5
weight		6g	23g	27g

For GM series

- x=5: gauze filter ZE17
- x=6: sintered inox filter ZE21
- x=9: integrated element filter made of PTFE and protective basket ZE16

For VM series

- x=5: sintered inox filter ZE13
- x=9: integrated element filter made of PTFE and protective basket ZE14

For OM series

- x=5: open protective basket made of plastic
- x=9: integr. element filter made of PTFE

Special version available on request.

User instructions

Install the MELA®-*sensing modules* at a place in the room or equipment where characteristic levels of humidity occur.

The proximity of heat sources, installation on external walls or installation in a splash area are to be avoided; ensure good ventilation of the sensor element.

The specified minimum air speeds and the operating voltage-adapted current at current-output (diagram) should be complied with. Deviations may lead to additional corrupted measurement readings because the sensor self-heats.

Dew formation and splashes do not damage the sensing modules, although corrupted measurement readings are recorded until all the moisture on and directly around the sensor element has dried up.

Dust does not cause any harm, however, it does affect dynamic performance.

If there is an excessive build-up of dust then you can unscrew the protective cap ZE16 resp. ZE14 on the series .../9 and carefully rinse the sensor head with distilled water. The element filter made of PTFE is not exchangeable.

On the series .../5 and .../6 the stainless steel sinter filter ZE21 and ZE13 can also be unscrewed and rinsed out with distilled water. Loose dirt can also be removed from the measuring element by blowing it off or by rinsing it carefully with distilled water. In order to avoid corrupted measurement readings, only screw the above mentioned sintered inox filter back on when they are completely dry. Do not touch the highly sensitive sensor element.

Please consult the *application instructions* for the sensing elements (product info sheet no. A 1) or check with the manufacturer for further information which you need to bear in mind when using humidity sensors with capacitive sensing elements.

In order to check functioning in the place of installation, we recommend that you use the MELA®-**ZE31/1-type humidity standard** with a **ZE 33-type auxiliary adapter** (product info sheet no. F 5.2).

Load at current output

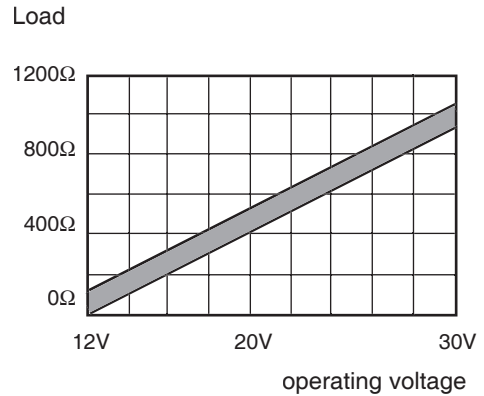

Tolerance validity range for humidity

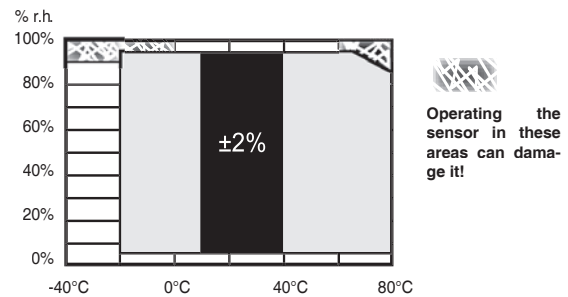

Dimensions

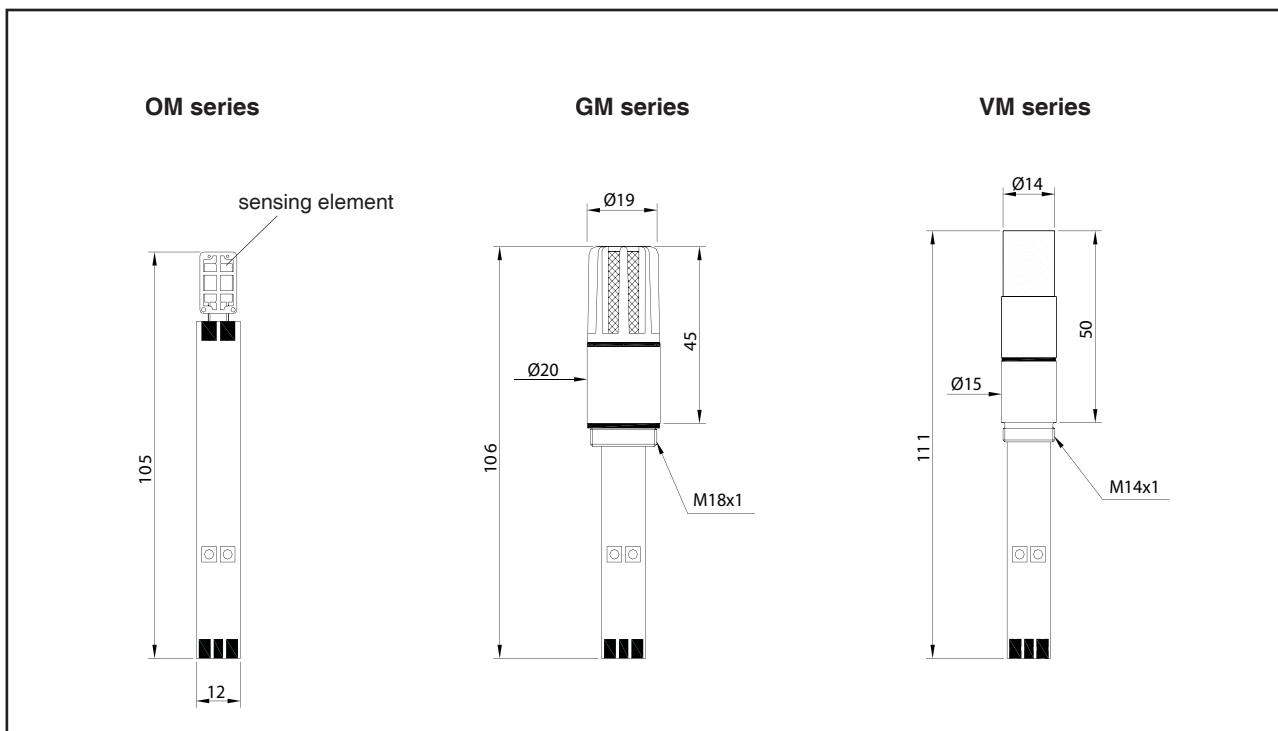

Connection diagram

Humidity/temperature sensing modules

Humidity sensing modules series OM, GM, VM

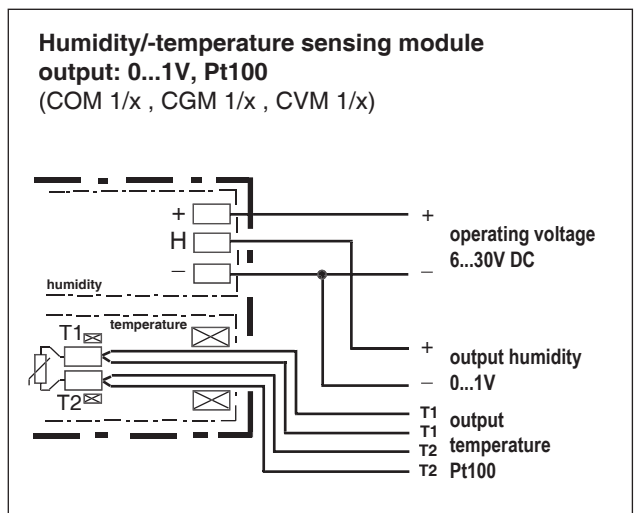
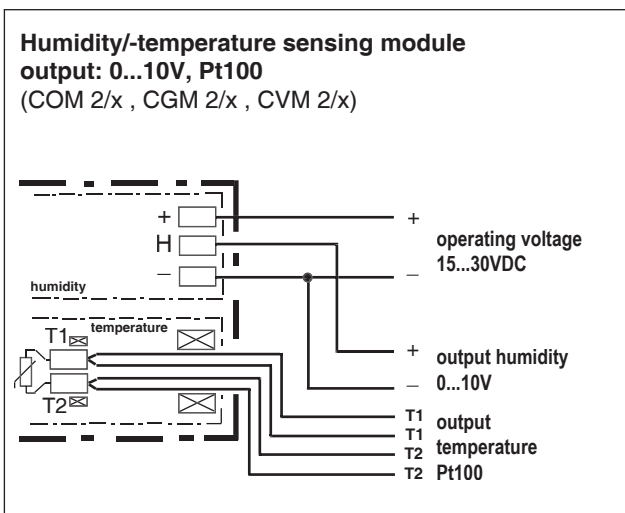
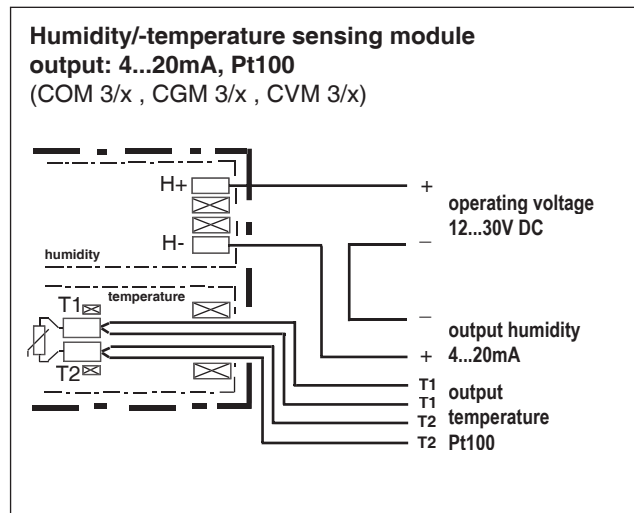
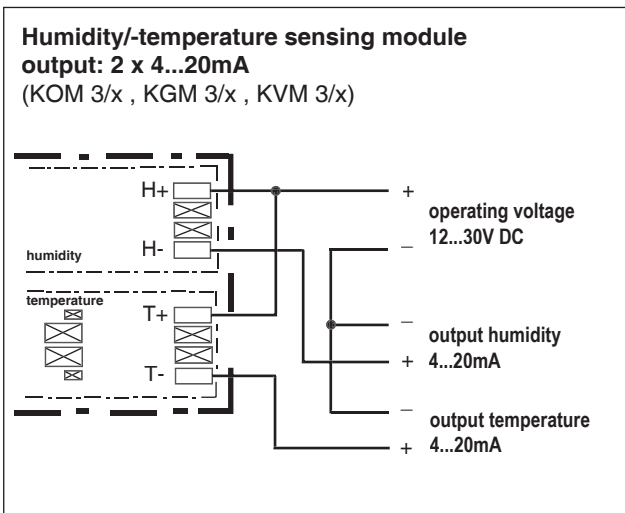
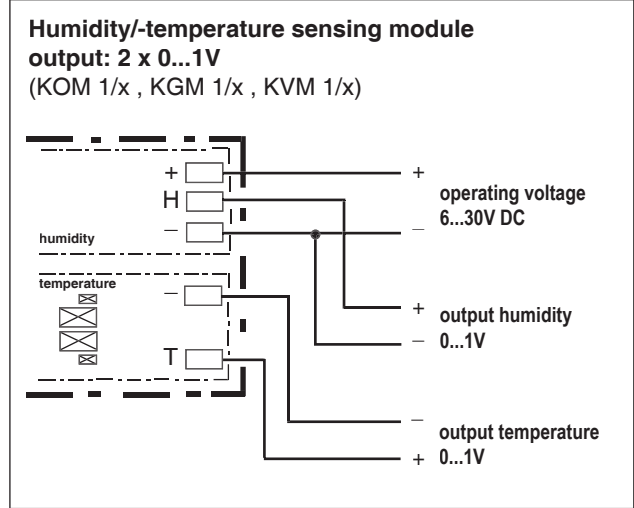
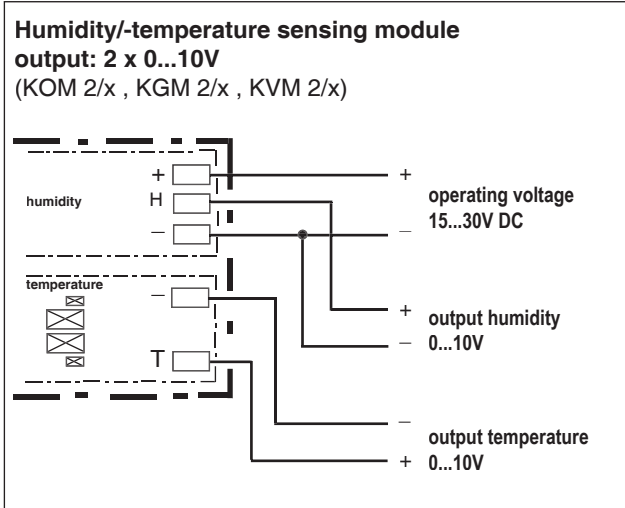

Connection diagram

Humidity/-temperature sensing modules

Humidity sensing modules series OM, GM, VM

