

User manual

Firmware versions V1.1-1.2
19.10.05

MTR262

Universal wireless transmitter
Pt100, TC, mV, mA and V inputs

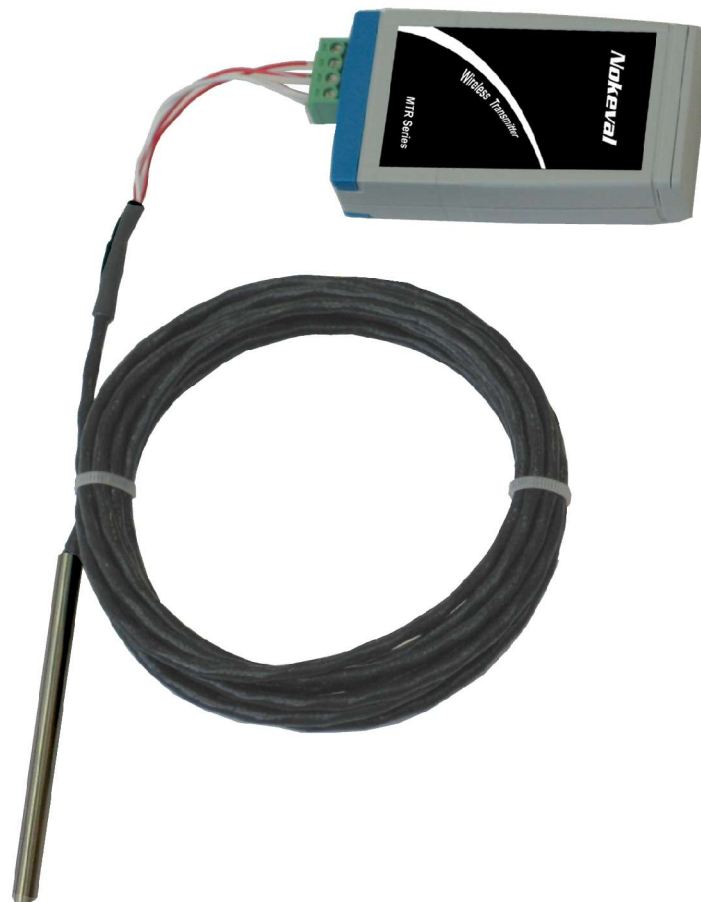

Nokeval

DESCRIPTION

MTR262 is a battery powered, universal input wireless transmitter. It is housed in a compact plastic enclosure and equipped with a 6-terminal detachable screw post connector. It has an internal circuit board antenna for a radio coverage area of up to 100 meters in free space.

The wireless concept allows easy implementation, installation and expansion of a measuring system even in difficult locations and installation sites. The transmitter is programmable for transmission intervals from 5 seconds to 5 minutes and for the following inputs: Pt100, Ni, Cu, universal thermocouple (mV + cold junction temperature), ohms, millivolts, milliamperes and volts up to 100 VDC.

SPECIFICATIONS

Inputs

Pt100

Range	-200...700 °C
Accuracy	0.05% rdg + 0.25°C
Thermal Drift	0.02°C/°C

Ni100

Range	-60...180 °C
Accuracy	0.05% rdg + 0.25°C
Thermal Drift	0.02°C/°C

Cu10

Range	-200...260 °C
Thermal Drift	0.02°C/°C

Thermocouples

Accuracy	Cold junction
	0...40 °C ±0.75 °C
	-30...60 °C ±1.5 °C

Thermocouple: See mV

mV

Range	-30...2000 mV
Accuracy	0.05 % rdg + 0.01 mV
Thermal Drift	50 ppm/°C
Load	>1 MΩ

V

Range	-600 mV...100 V
Accuracy	0.05 % rdg + 0.01 V
Thermal Drift	50 ppm/°C
Load	>1 MΩ

mA

Range	0...25 mA
Accuracy	0.008 mA
Thermal Drift	50 ppm/°C
Load	50...80 Ω

Environment

Oper. temperature -30...+60 °C
Protection class: IP20

Compatible radio devices

Nokeval MTR and RTR series devices.

Supply voltage

Voltage 2.5...3.5 V
Battery 3 V CR 2032

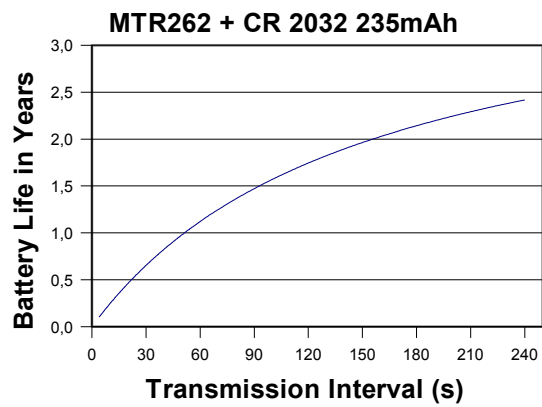

Other

External dimensions 45 mm x 81 mm x 18.5 mm
Weight 36 g
Connectors 1.5 mm², detachable

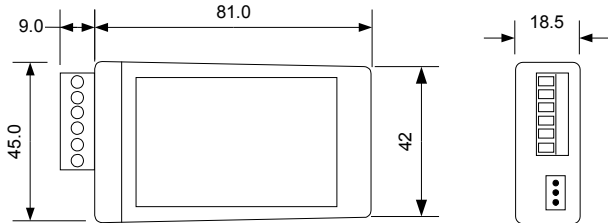

Frequency license free 433.92MHz
subband e according to
ERC/REC 70-03

Transmission range
open space up to 100 m
indoor 10...50 m

Regulations

EMC directive

- EMC immunity EN 61326
- EMC emissions EN 61326, class B

R&TTE directive

- EN 300 220 class 3, Transmitter power class 8 (10 mW)
- EN 301 489
- EN 300 339

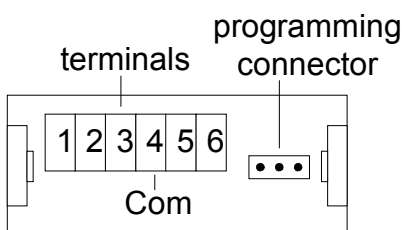

INSTALLING

Installing/replacing the battery

Open the back plate using a small flat-bladed screwdriver. Remove the back plate and the top part of the case and install the battery (CR 2032 3V) to the slot plus side upwards. Close the case and attach the back plate.

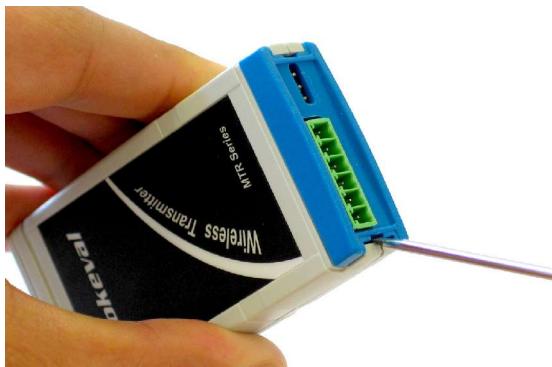

1. Open the case



2. Install the battery to the slot

Installation to a field enclosure (option)

The device can be installed into an optional plastic (ABS) field enclosure. The field enclosure's protection class is IP65 and it has a PG9 gland for sensor cable. The external dimensions of the enclosure are 130 mm x 80 mm x 35 mm.



Connectors

MTR262 connectors

The device has a 6-terminal detachable screw post connector and a programming connector.

Connections

Resistance input

Two-wire connection

Connect the sensor to terminals two and three. Terminal two is the measurement current source. Note that terminals one and two must be connected, as do terminals three and four.

Two-wire measurement is not recommended to be used with long wires, because the resistance of wires affects to the result.

You must enable four-wire (4W) measurement in settings.

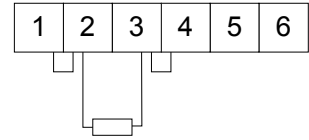

Three-wire connection

Connect the sensor to terminals two, three and four. Terminal two is the measurement current source. Note that all conductors should be equal in length and have equal cross-sectional area.

You must disable four-wire (4W) measurement in settings.

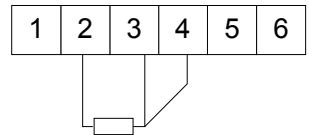

Four-wire connection

Connect the sensor to terminals one, two, three and four. Terminal two is the measurement current source. Four-wire measurement is the most accurate way to measure sensor's resistance because the resistance differences in conductors have no effect.

You must enable four-wire (4W) measurement in settings.

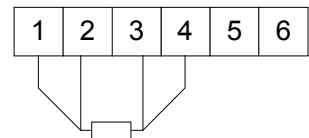

Thermocouples and mV

Connect the sensor or mV input to terminals three and four.

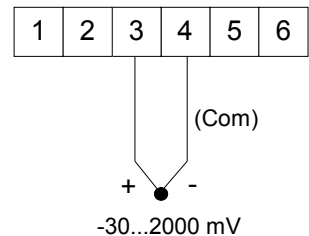

mA input

Connect the mA input to terminals four and six.

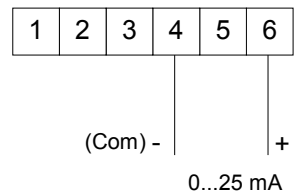

V input

Connect the voltage input to terminals four and five.

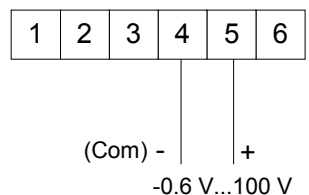

Programming connector

Use RS232-POL or POL cable and POL – pin header adaptor to connect the device to PC's serial port or Nokeval 6790 hand held programmer.

SETTINGS

Connection settings

Use Mekuwin program or Nokeval 6790 hand held programmer to configure the device. You can download Mekuwin from Nokeval's web site for free.

Communication settings for configuration:

- Baud rate 9600
- protocol SCL
- address 0

Menu

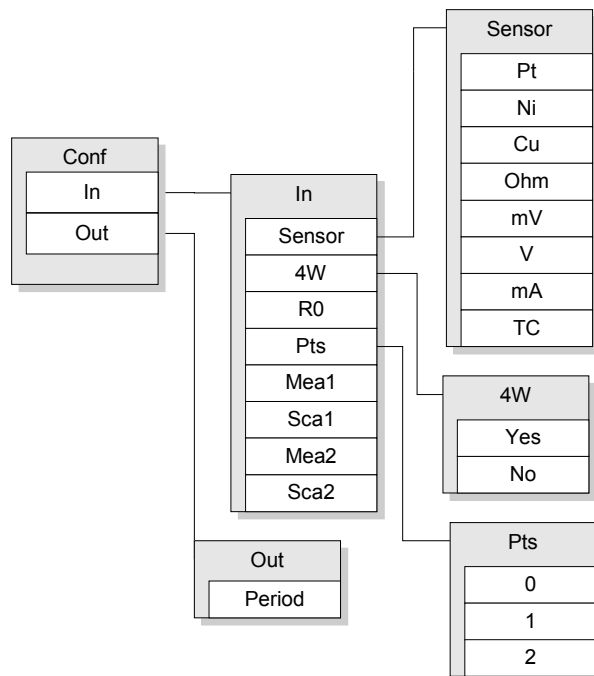

In submenu

Sensor

Input range and sensor selection.

- **Pt, Ni and Cu** Resistance thermometers (RTD's). The nominal resistance is set in R0 (see below). The reading is in Celsius.
- **Ohm**: Resistance input. The resistor is connected in two-wire, three-wire or four-wire connection. The reading is in ohms.
- **mV**: Voltage input -30...2000 mV.
- **V**: Voltage input -600 mV...100 V.
- **mA**: Current input 0...25 mA.
- **TC**: Thermocouples.

Note! MTR262 doesn't do linearization. If TC is selected, the result is sent in millivolts. In addition, the device measures and sends the cold junction temperature. The result is linearized in the receiving system (for example, PromoLog or RTR970PRO)

4W

- No: Three-wire RTD connection.
- Yes: Four-wire RTD connection.

R0

The nominal resistance of a resistive temperature sensor. With Pt and Ni sensors, this is the resistance at 0°C, e.g. with Pt100 set R0=100. With Cu the nominal resistance is given at 25°C.

If the real resistance of the sensor at the nominal temperature is known, it can be fed here, in order to cancel the sensor error.

Pts

Number of scaling points. The scaling means converting the reading to represent some other (engineering) reading. The scaled value is used on the display, serial output, analog outputs, and alarms.

- **0**: No scaling.
- **1**: One point offset correction. The reading corresponding to Mea1 is scaled to be Sca1 when displayed, using appropriate offset value.
- **2**: Two point scaling. Readings from Mea1 to Mea2 are scaled to be Sca1 to Sca2 on the display and other outputs. Any values can be used, these do not have to be the end points.

Mea1, Sca1, Mea2, and Sca2

Scaling points. Visibility of these settings depend on the Pts setting. Unscaled reading Mea1 is converted to Sca1, and Mea2 to Sca2. These scaling points can be conveniently used to **calibrate a sensor-transmitter pair** in a thermal bath. First set the scaling off by setting Pts=0. Apply one or two known temperatures to the sensor and write down the displayed and the real temperatures. Then set Pts to 1 or 2 depending on the number of calibration points, and write the first reading in Mea1 and the real temperature in Sca1. And the same with Mea2 and Sca2 if two points are calibrated.

Out submenu

Period

Number of periods between consecutive transmissions. The minimum value for this setting is two and maximum value is 127. One period is approximately 2.7 seconds (25 °C). The duration of a period depends on temperature and varies from 1.5 to 3 seconds. It is not recommended to set the period value smaller than necessary because it has a significant effect on battery life (see graph on page 2).

Period	Nominal transmission interval
2	5 s
11	30 s
22	1 min
67	3 min
127	5 min 40 s

The maximum number of radio transmitters in a coverage area is limited by radio standards. The use of repeaters reduces the maximum number of transmitters because repeaters use the same frequency as the transmitters. The following table shows the maximum number of allowed radio transmitters

Transmission Interval (s)	Receiver	Receiver and 1 repeater	Receiver and 2 repeaters
	Maximum number of transmitters		
5	22	11	7
10	43	22	14
20	87	43*	29
30	130	65	43
40	174	87	58
50	217	109	72
60	261	130	87
70	304	152	101
80	348	174	116
90	391	196	130
120	522	261	174
240	1043	522	348

Nokeval
 Yrittäjätu 12
 37100 Nokia
 Finland
 Tel +358 3 3424800
 Fax +358 3 3422066
 www.nokeval.com

For example, if you have transmission interval 40 seconds and one repeater, the maximum number of transmitters is 43*.

The collision probability of radio data packets increases when the number of transmitters in a coverage area increases or the transmission interval decreases. The following picture shows how the collision probability raises as the number of transmitters increases.

