

User Manual
Firmware versions V1.0-1.2
31.10.2007

MTR165

Wireless transmitter mV, mA and 100V inputs

MTR265

Wireless transmitter Pt100, TC and mV inputs



Nokeval

DESCRIPTION

MTR165 and MTR265 are battery powered wireless transmitters. MTR165 has mV, mA and V inputs whereas MTR265 is designed for temperature sensors and has Pt100, TC and mV inputs. Both transmitters are housed in an IP65 rated field enclosure and equipped with a standard M12 connector for sensor attachment.

The transmitters have a long range whip antenna for a radio coverage area of up to 500 meters in free space. MTR165 and MTR265 are programmable for transmission intervals from 5 seconds to 5 minutes. The wireless concept allows easy implementation, installation and expansion of a measuring system even in difficult locations and installation sites.

Manufacturer

Nokeval Oy
Yrittäjätie 12
FI-37100 Nokia
Finland

Tel: +358 3 3424800
Fax: +358 3 3422066
Web: www.nokeval.com
Technical support: support@nokeval.com

INSTALLING

Installing/replacing the battery

Detach the device from the metal wall mounting bracket and screw off the top part of the case and install the battery (CR 2032 3V) to the slot plus side upwards and close the case.

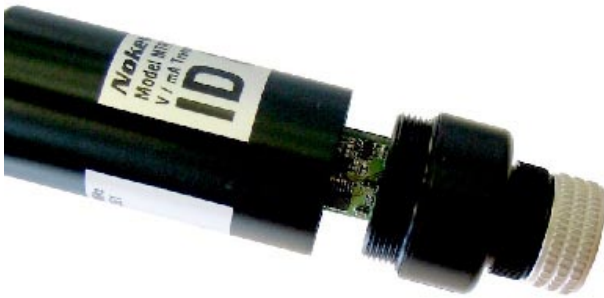

1. Open the case

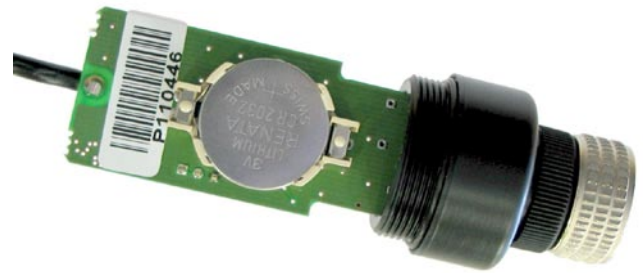

2. Install the battery to the slot

ATTENTION! Turn the battery around before use.

When the device is delivered the battery is reversed on purpose. Install the battery as shown in the picture above.

If the device has been in cold environment wait until the device's temperature has reached the ambient temperature before opening the case to prevent condensation in the device.

Connectors

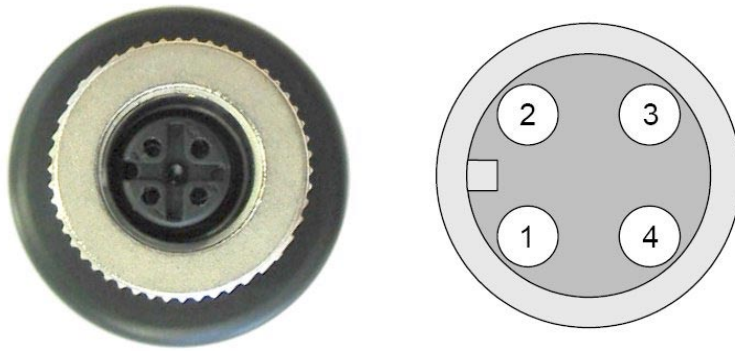

The device has a standard M12 connector.

MTR165 connections

mV

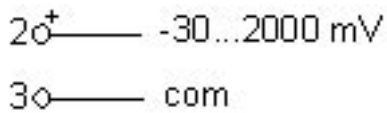

mA

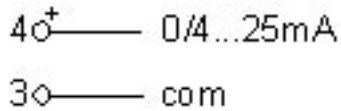

V

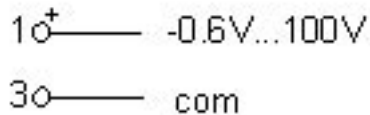

MTR265 connections

Pt100/Ni/Cu/Ohm

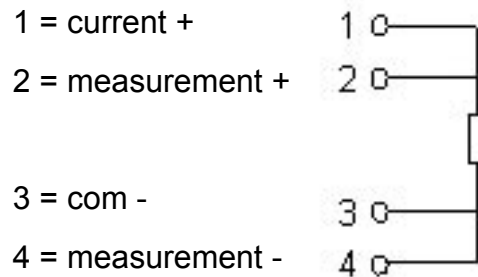

Leave terminal two unconnected if three-wire connection is used.

TC/mV

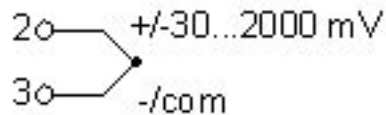

Optional screw connector M12S-KO for sensor cable is available.

Transmitter placement

Typical coverage range indoors varies from fifty to one hundred meters depending on the obstacles between the transmitter and receiver. The best signal level is achieved when there is a line of sight between the transmitter and receiver. Walls and obstacles, especially closed metal structures, attenuate the signal and therefore decrease the coverage area. It is recommended to avoid installing transmitters in such places if possible.

To achieve the best coverage area, place the transmitter so that its antenna is in vertical position.

Indicator lights

The device has a transmit indicator light that flashes every time measurement data is sent.

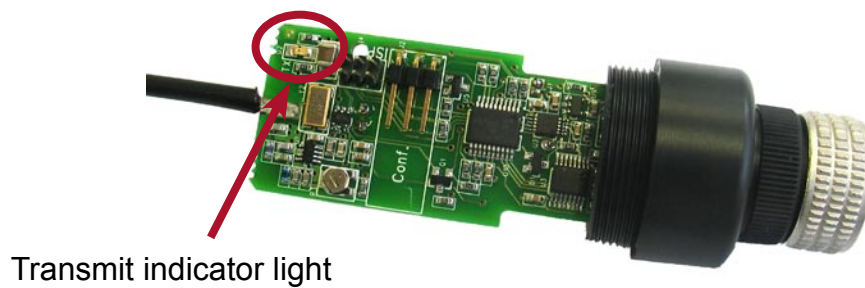

Connection settings

Use Mekuwin program or Nokeval 6790 hand held programmer to configure the device. You can download Mekuwin from Nokeval's web site for free.

Communication settings for configuration:

Baud rate 9600
 protocol SCL
 address 0

Programming connector

Use RS232-POL or POL cable and POL – pin header adaptor to connect the device to PC's serial port or Nokeval 6790 hand held programmer. When the programming connector is connected the device sends measurement data about three times per second. When the configuration connection is open no measurement data is sent.

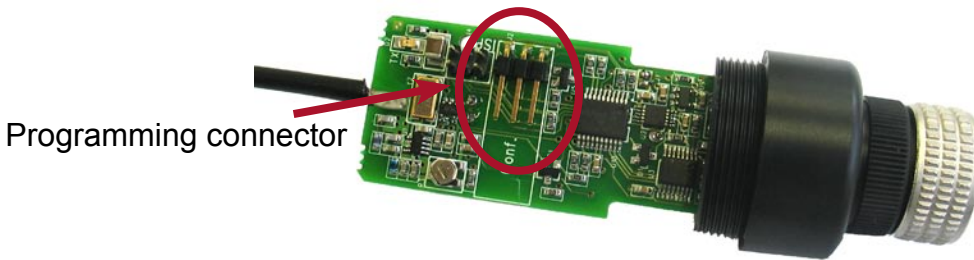

Menus

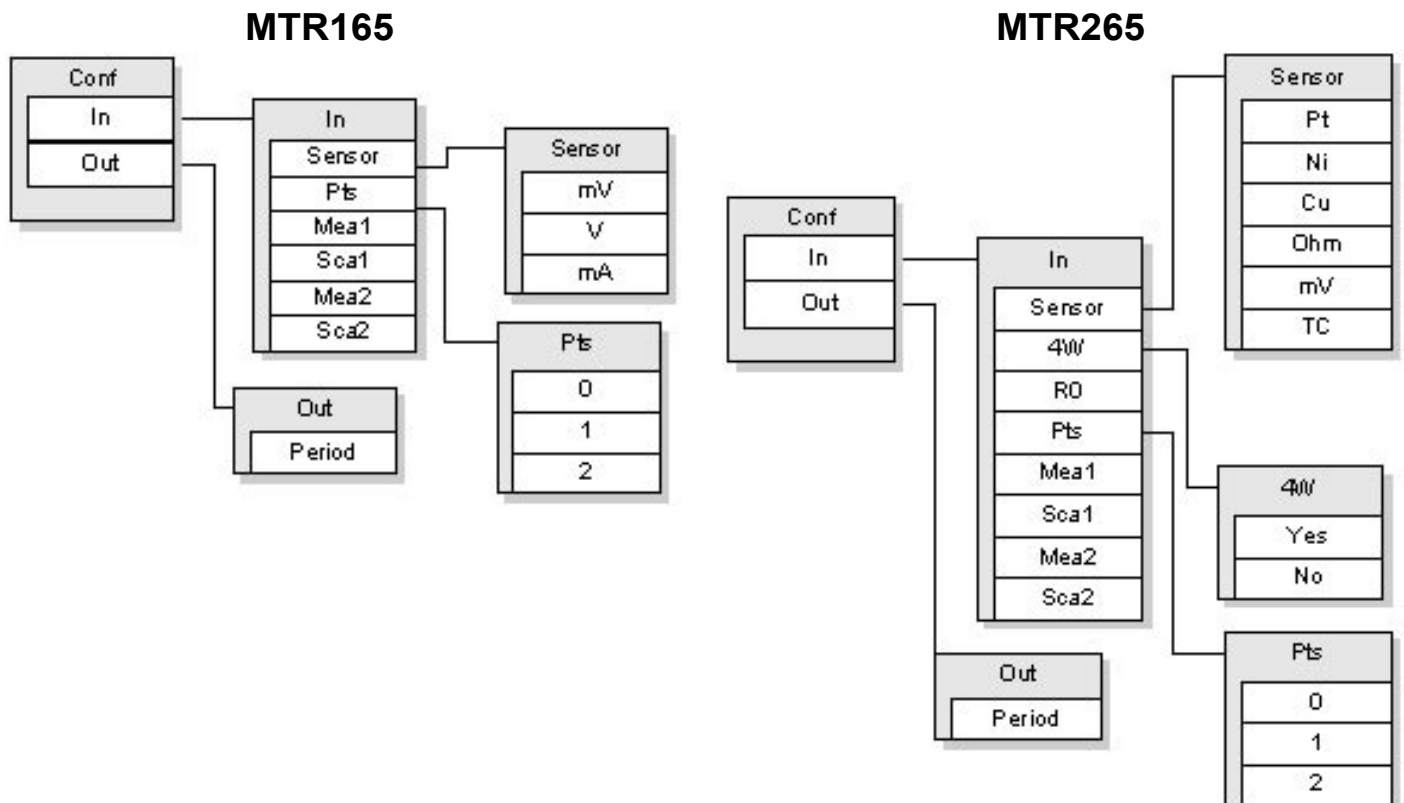

In submenu

Input submenu contains the input settings.

Sensor

Input range and sensor selection.

- **Pt, Ni and Cu** Resistance thermometers (RTD's). The nominal resistance is set in R0 (see below). The reading is in Celsius.
- **Ohm**: Resistance input. The resistor is connected in two-wire, three-wire or four-wire connection. The reading is in ohms.
- **mV**: Voltage input -30...2000 mV
- **V**: Voltage input -600 mV...100 V
- **mA**: Current input 0...25 mA
- **TC**: Thermocouples
 Note! MTR265 doesn't do linearization. If TC is selected, the result is sent in millivolts. In addition, the device measures and sends the cold junction temperature. The result is linearized in the receiving system (for example, PromoLog or RTR970PRO)

4W

- No: Three-wire RTD connection.
- Yes: Four-wire RTD connection.

R0

The nominal resistance of a resistive temperature sensor. With Pt and Ni sensors, this is the resistance at 0°C, e.g. with Pt100 set R0=100. With Cu the nominal resistance is given at 25°C.

If the real resistance of the sensor at the nominal temperature is known, it can be fed here, in order to cancel the sensor error.

Pts

Number of scaling points. The scaling means converting the reading to represent some other (engineering) reading. The scaled value is used on the display, serial output, analog outputs, and alarms.

- **0**: No scaling.
- **1**: One point offset correction. The reading corresponding to Mea1 is scaled to be Sca1 when displayed, using appropriate offset value.
- **2**: Two point scaling. Readings from Mea1 to Mea2 are scaled to be Sca1 to Sca2 on the display and other outputs. Any values can be used, these do not have to be the end points.

Mea1, Sca1, Mea2, and Sca2

Scaling points. Visibility of these settings depend on the Pts setting. Unscaled reading Mea1 is converted to Sca1, and Mea2 to Sca2. These scaling points can be **conveniently used to calibrate a sensor-transmitter pair** in a thermal bath. First set the scaling off by setting Pts=0. Apply one or two known temperatures to the sensor and write down the displayed and the real temperatures. Then set Pts to 1 or 2 depending on the number of calibration points, and write the first reading in Mea1 and the real temperature in Sca1. And the same with Mea2 and Sca2 if two points are calibrated.

Out submenu

Output submenu contains the output settings.

Period

Number of periods between consecutive transmissions. The minimum value for this setting is two and maximum value is 127. One period is approximately 2.7 seconds (25 °C). The duration of a period depends on temperature and varies from 1.5 to 3 seconds. It is not recommended to set the period value smaller than necessary because it has a significant effect on battery life.

Period	Nominal Transmission Interval
2	5 s
11	30 s
22	1 min
67	3 min
127	5 min 40 s

The maximum number of radio transmitters in a coverage area is limited by radio standards. The use of repeaters reduces the maximum number of transmitters because repeaters use the same frequency channel as transmitters. The following table shows the maximum number of allowed radio transmitters in a coverage area.

Transmission Interval (s)	Receiver	Receiver and 1 repeater	Receiver and 2 repeaters
	Maximum number of transmitters		
5	22	11	7
10	43	22	14
20	87	43*	29
30	130	65	43
40	174	87	58
50	217	109	72
60	261	130	87
70	304	152	101
80	348	174	116
90	391	196	130
120	522	261	174
240	1043	522	348

For example, if you have transmission interval of 20 seconds and one repeater, the maximum number of transmitters is 43*.

The collision probability of radio data packets increases when the number of transmitters in a coverage area increases or the transmission interval decreases. The following pictures show how the collision probability raises as the number of transmitters increases.

MTR165

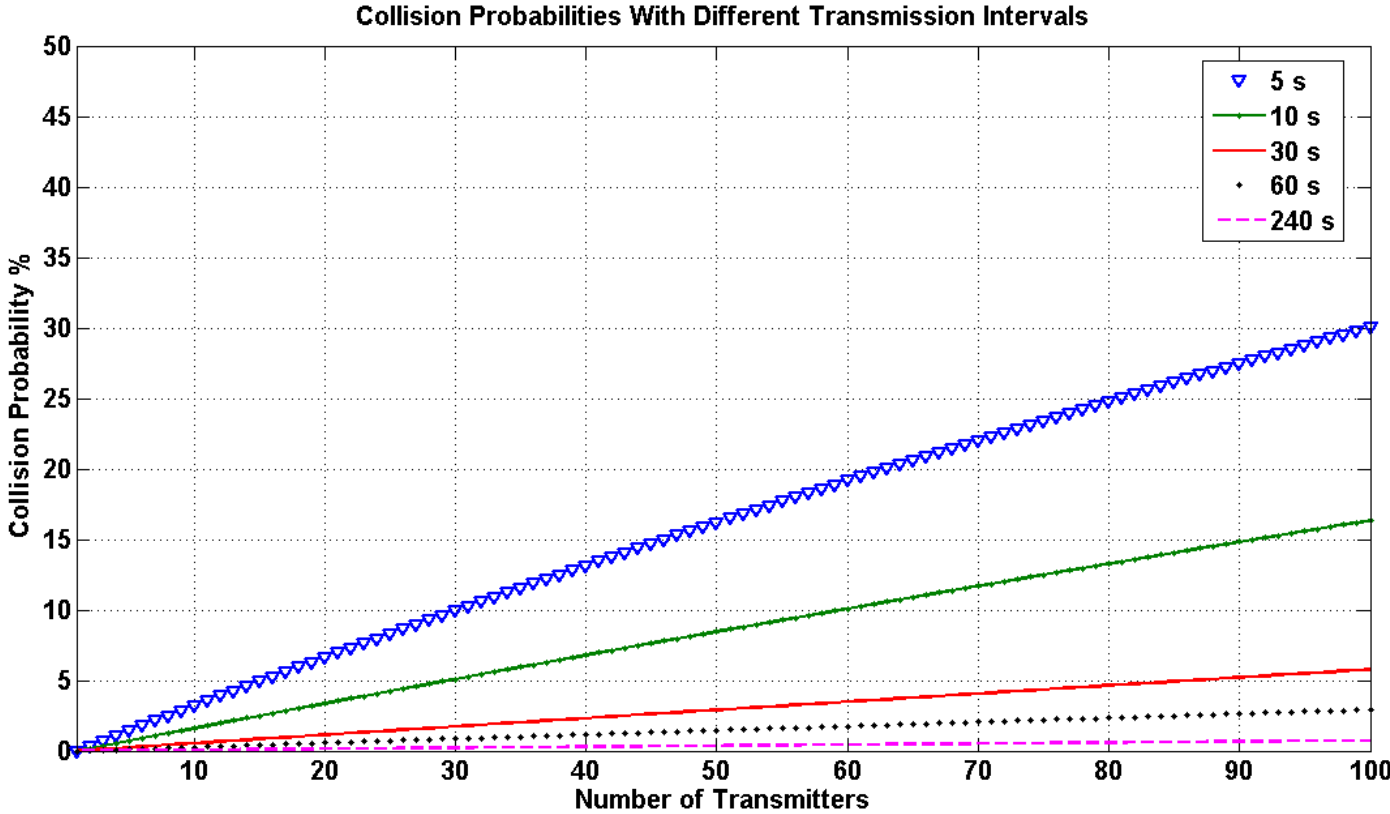

MTR265

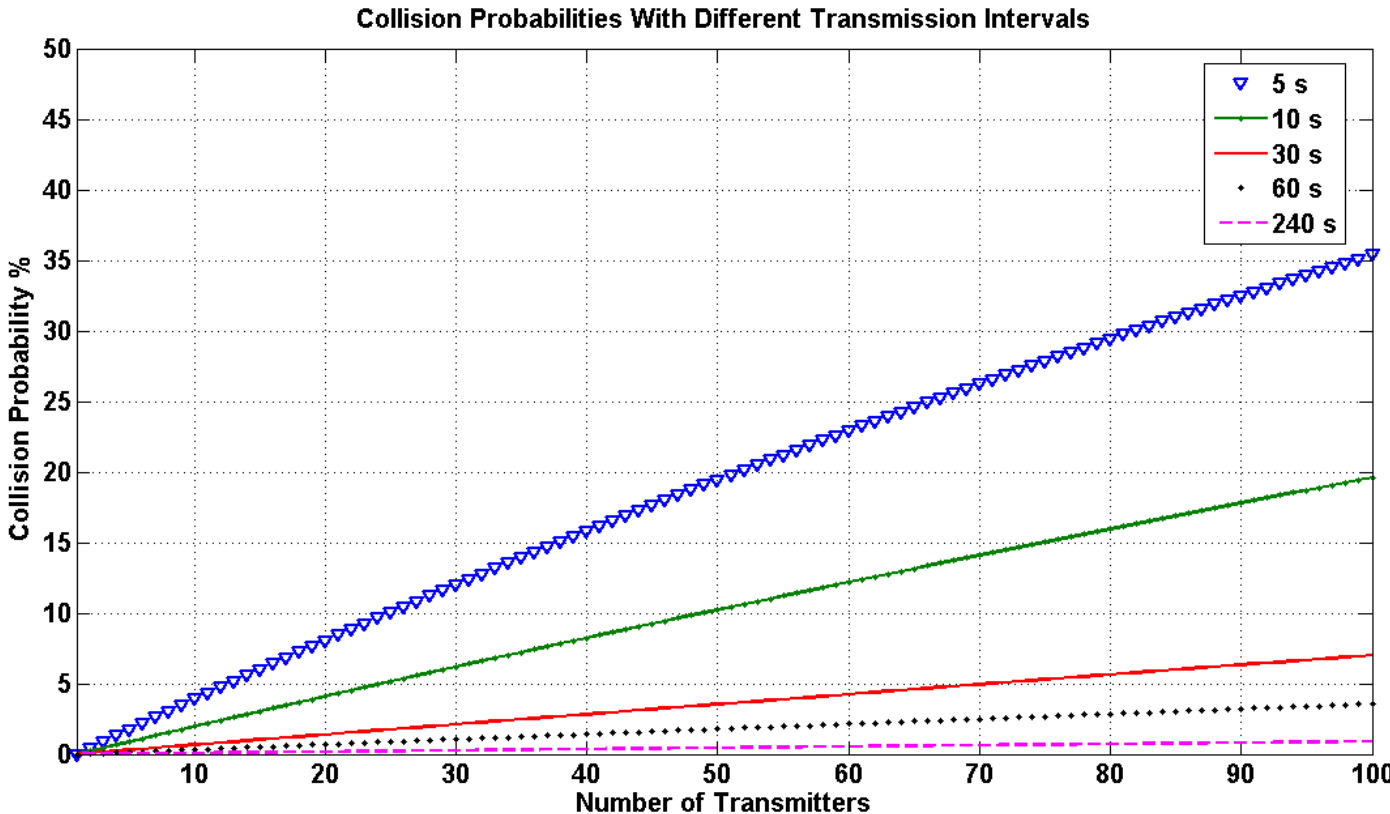

SPECIFICATIONS

Input

MTR165

mV

Range	-30...2000 mV
Accuracy	0.05 % rdg + 0.01 mV
Thermal Drift	50 ppm/°C
Load	>1 MΩ

V

Range	-600 mV...100 V
Accuracy	0.05 % rdg + 0.01 V
Thermal Drift	50 ppm/°C
Load	>1 MΩ

mA

Range	0...25 mA
Accuracy	0.008 mA
Thermal Drift	50 ppm/°C
Load	50...80 Ω

MTR265

Pt100

Range	-200...700 °C
Accuracy	0.05% rdg + 0.25°C
Thermal Drift	0.02°C/°C

Ni100

Range	-60...180 °C
Accuracy	0.05% rdg + 0.25°C
Thermal Drift	0.02°C/°C

Cu10

Range	-200...260 °C
Accuracy	0.05% rdg + 0.25°C
	0.02°C/°C

Thermocouples

Accuracy	Cold junction
	0...40 °C ±0.75 °C
	-30...60 °C ±1.5 °C
	Thermocouple
	See mV

mV

Range	-30...2000 mV
Accuracy	0.05 % rdg + 0.01 mV
Thermal Drift	50 ppm/°C
Load	>1 MΩ

Battery

Model CR2032
 Nominal voltage 3.0 V
 Chemical system LiMnO₂

Estimated battery life time (25°C)

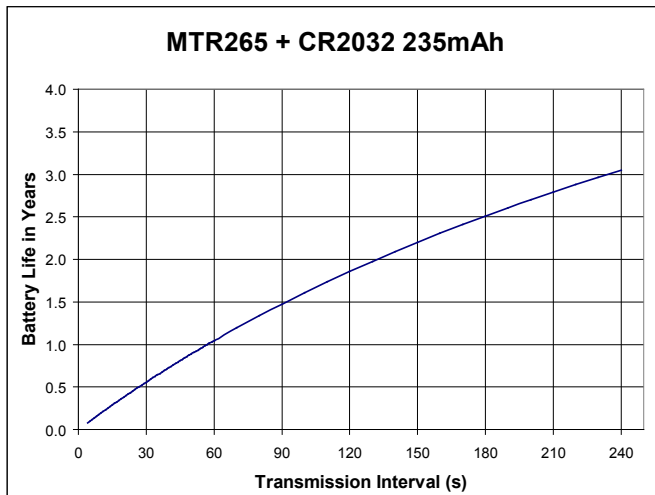

Battery life time will be shorter in extreme temperature conditions.

Used batteries are hazardous waste. Same battery model must be used to replace a dead battery.

Environment

Oper. temperature -20...+60 °C
 Storage temperature -40...+70 °C
 Protection class IP66

Radio transmitter

License free 433.92MHz subband f according to ERC/REC/70-03.

Coverage Area

Open space up to 500 m
 Indoors 50-100 m (typically)

External dimensions

Device:

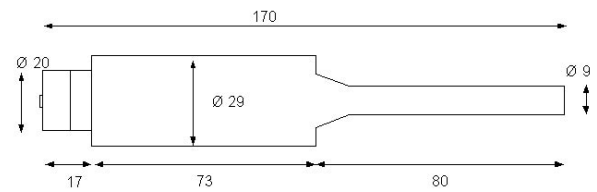

Wall mounting bracket:

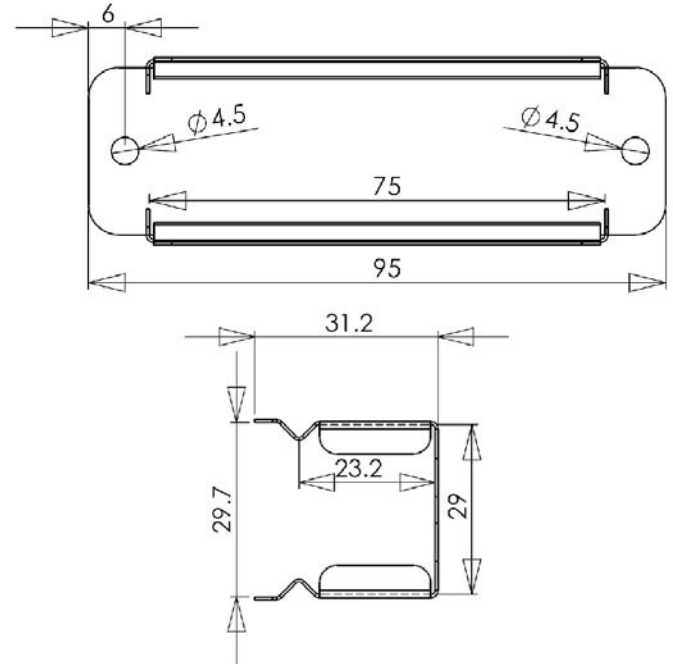

Dimensions shown in millimeters.

Other

Weight 65 g
 Connectors M12 and POL programming connector

Compatible radio receivers

Nokeval MTR, RTR and FTR series radio receivers.

Regulations

EMC directive

- EMC immunity EN 61326
- EMC emissions EN 61326, class B

R&TTE directive

- EN 300 220 class 3,
Transmitter power class 8 (10 mW)
- EN 301 489
- EN 300 339

